

# Extrapolated elliptic regularity and application to the van Roosbroeck system of semiconductor equations

Hannes Meinlschmidt, Joachim Rehberg

April 8, 2020

In this paper we present a general *extrapolated elliptic regularity* result for second order differential operators in divergence form on fractional Sobolev-type spaces of negative order  $X_D^{s-1,q}(\Omega)$  for  $s > 0$  small, including mixed boundary conditions and with a fully nonsmooth geometry of  $\Omega$  and the Dirichlet boundary part  $D$ . We expect the result to find applications in the analysis of nonlinear parabolic equations, in particular for quasilinear problems or when treating coupled systems of equations. To demonstrate the usefulness of our result, we give a new proof of local-in-time existence and uniqueness for the van Roosbroeck system for semiconductor devices which is much simpler than already established proofs.

**Keywords:** Elliptic regularity, nonsmooth geometry, Sneiberg stability theorem, fractional Sobolev spaces, van Roosbroeck system, semiconductor equations

**AMS classification (2020):** 35J25, 35B65, 35R05, 35Q81, 92E20

## 1 Introduction

Let  $\Omega \subset \mathbb{R}^d$  be a bounded domain with nonsmooth boundary of which the set  $D$  is a subset. Let further  $\rho$  be a bounded measurable uniformly-a.e. positive definite coefficient matrix defined on  $\Omega$ , and let  $-\nabla \cdot \rho \nabla$  be the associated second-order differential operator in divergence form. One may consider this operator as the principal part of a possibly more general linear differential operator. Assume that for some  $q \in (1, \infty)$  the following optimal elliptic regularity property holds true:

$$-\nabla \cdot \rho \nabla u \in W_D^{-1,q}(\Omega) \implies u \in W_D^{1,q}(\Omega), \quad (1.1)$$

where  $W_D^{-1,q}(\Omega) := (W_D^{1,q'}(\Omega))^*$ , the space of antilinear functionals on  $W_D^{1,q'}(\Omega)$ , and the subscript  $D$  refers to zero boundary trace on  $D$ . Of course, the probably best known

optimal elliptic regularity result is the Hilbert space case  $q = 2$  where (1.1) is always true under our assumptions on  $\rho$  if  $D$  is sufficiently large such that  $\mathbf{1} \notin W_D^{1,2}(\Omega)$ . There are countless works extending this result also to (1.1) for the integrability scale  $q > 2$ ; we mention exemplarily [9, 22, 26, 27] where also mixed boundary conditions and *nonsmooth* data  $\Omega$  and  $\rho$  are treated. In this paper we establish an optimal elliptic regularity result for a *differentiability* scale such as  $H_D^{s-1,q}(\Omega) = (H_D^{1-s,q'}(\Omega))^*$  starting from (1.1). More precisely, we show that if (1.1) holds true for some  $q \in (1, \infty)$  and if there is  $\tau > 0$  such that each component  $\rho_{ij}$  of the coefficient matrix function is a multiplier on the Bessel potential space  $H_D^{\tau,q}(\Omega)$ , then there exists a number  $\bar{s} \in (0, \tau]$  such that

$$-\nabla \cdot \rho \nabla u \in H_D^{s-1,q}(\Omega) \quad \implies \quad u \in H_D^{1+s,q}(\Omega) \quad (1.2)$$

for  $s \in (-\bar{s}, \bar{s})$ . (We give precise definitions of function spaces and assumptions in Section 2 below.) The result is obtained from (1.1) by an *extrapolation* technique: We establish that  $W_D^{1,q}(\Omega)$  and  $W_D^{-1,q}(\Omega)$  are “interior points” in the interpolation scale of Bessel potential spaces and the dual scale, and that  $-\nabla \cdot \rho \nabla$  is compatible with that scale. Then the Sneiberg extrapolation theorem ([56]) gives the result. This is what is meant by the titular *extrapolated elliptic regularity*. We remark that (1.1) is already nontrivial to have, in particular if  $q$  is not around 2. The extrapolation technique and recent interpolation results also allow to obtain (1.2) for the Slobodetskii scale  $W_D^{1+s,q}(\Omega)$  and  $W_D^{s-1,q}(\Omega)$  as a byproduct. Moreover, we in fact establish (1.2) not only for pure second-order operators but also for such including lower order terms and in particular boundary forms arising from Robin boundary conditions. Thanks to a quantitative version of the Sneiberg theorem which was recently established in [3], we can also provide property (1.2) and bounds on the inverse operators uniform in the given data. Such uniform results are extremely useful in the treatment of nonautonomous or even quasilinear evolution equations, cf. [41, 47, 48].

Note that while inferring (1.2) from (1.1) may feel like an “expected” result, the necessary groundwork behind the reasoning is highly nontrivial since we suppose essentially no smoothness in the data at all. This is in particular the case since (1.2) for  $q > d$  (ambient space dimension) is of elevated interest to us for conceptual reasons in the treatment of abstract nonlinear evolution equations. Let us take this for granted at the moment; we explain it in detail in the next subsection of this introduction. It is known since the sixties that in the present case of nonsmooth data, one in general cannot expect  $q$  in the assumed (1.1) to be larger than a prescribed number  $\bar{q} > 2$ , see for example [17, 42, 52]. (Due to Sobolev embeddings, the size of  $s$  in (1.2) is thus also limited in the general case.) This makes already the assumption (1.1) sensible for  $q > d = 3$ . In fact, to the best of the authors’ knowledge, the only comparable results for (1.2) which include mixed boundary conditions and nonsmooth data are [30], for a relatively restricted geometry, and [27], with very general geometry. Both works are limited to  $q$  close to 2 in (1.2), starting from the Lax Milgram result. Another conceptual obstacle is the availability of a suitable interpolation theory framework for  $H_D^{\sigma,q}(\Omega)$  spaces also for  $q \neq 2$ . Fortunately, both issues have been resolved recently:

- (i) In [12], the authors collect a rich setting of geometric constellations for  $\Omega, D$  and the coefficient functions  $\rho$  under which (1.1) is satisfied for  $q > d = 3$ . This includes a wide array of quite nonsmooth situations occurring in real-world problems.
- (ii) In their seminal paper [6], Bechtel and Egert establish a comprehensive interpolation theory for the Bessel potential (and Sobolev Slobodetskii) scale in an extremely general geometric setup. Their work extends previously known results under similar geometric assumptions in [16] for the Hilbert scale corresponding to  $q = 2$ . (In fact, these older results were used in [27].)

We explicitly point out that both works are highly nontrivial and in turn rest on other difficult results. (See [12, Introduction] for more background.) Let us also note that already (1.1) for  $q > d$  itself has turned out to be an extremely valuable and well suited—one might even say, indispensable—property in the treatment of nonlinear and/or coupled systems of evolution equations with highly nonsmooth data arising in real-life problems, see e.g. [13, 29, 39, 40]. We next motivate why we need also the optimal regularity result (1.2) for  $q > d$  in the fractional Sobolev scales.

### Motivation and real-world example: semiconductor equations

One of the main areas where optimal elliptic regularity results like (1.2) are needed is the analysis of nonlinear evolution equations. We give a real-world example in Section 4 below by considering the van Roosbroeck system of semiconductor equations, but we expect many more applications to be susceptible to similar reasoning. For now, consider for example the following abstract Fokker-Planck type evolution equation posed in some Banach space  $X$  over some time interval  $J$  as a model problem:

$$\partial_t u - \nabla \cdot \mu \nabla u = \nabla \cdot u \mu \nabla (-\nabla \cdot \rho \nabla)^{-1} f + |\nabla u|^2 + g \quad \text{in } X, \quad (1.3)$$

where  $\mu$  is another matrix coefficient function of the same quality as  $\rho$ , while  $f$  and  $g$  are appropriate data, the latter e.g. coming from inhomogeneous Neumann boundary conditions. Such model equations are related to the *viscous Hamilton-Jacobi equation* or the *deterministic KPZ equation*; we exemplarily refer to [8, 21, 46]. One may imagine having obtained this abstract equation from eliminating the second equation in the abstract system

$$\begin{aligned} \partial_t u - \nabla \cdot \mu \nabla u - \nabla \cdot u \mu \nabla w &= |\nabla u|^2 + g, \\ -\nabla \cdot \rho \nabla w &= f. \end{aligned}$$

It turns out that in this situation, in order to deal with the quadratic nonlinearity in (1.3) in the framework of classical theory for semilinear equations ([45, Ch. 6]),  $X$  should be chosen as an interpolation space of the form  $[L^q(\Omega), W_D^{-1,q}(\Omega)]_{1-s}$  with parameters  $q > d$  and  $s \in (0, 1 - \frac{d}{q})$ ; this was observed in [25, Sect. 6], see also [13, Sect. 4.1]. We fix  $X$  to be such a space for the following. Note that  $X = [L^q(\Omega), W_D^{-1,q}(\Omega)]_{1-s}$

can indeed be identified with the (dual) Bessel potential space  $H_D^{s-1,q}(\Omega)$  under very mild assumptions on  $\Omega$  and the geometry of  $D$ . We also mention that dealing with the quadratic nonlinearity in (1.3) does *not* require explicit knowledge of the domains of the elliptic operators in  $X$ . This however changes when we consider the drift term for  $u$  where we assume that  $f$  is in general not more regular than generic elements of  $H_D^{s-1,q}(\Omega)$ —e.g. also arising from inhomogeneous Neumann boundary conditions—, because then we further have to assure that the operators  $\nabla \cdot u\mu\nabla(-\nabla \cdot \rho\nabla)^{-1}$  in (1.5) are bounded ones when considered on  $X$  in order to obtain a self-consistent abstract formulation. More precisely the domain of  $-\nabla \cdot \rho\nabla$  in  $X$  must be continuously embedded into the domain of  $\nabla \cdot u(t)\mu\nabla$  in  $X$  for  $t \in J$ . The optimal case and thus the natural candidate for the domain of definition for these elliptic operators in  $X = H_D^{s-1,q}(\Omega)$  is the space  $H_D^{1+s,q}(\Omega)$ , cf. e.g. [58, Ch. 5.7.1]. While the actual domains of the operators  $\nabla \cdot u(t)\rho\nabla$  in  $X$  will in general not coincide with  $H_D^{1+s,q}(\Omega)$  and vary with  $t$  without further assumptions, one easily observes that  $H_D^{1+s,q}(\Omega)$  is indeed the largest space which will embed continuously into every such  $t$ -dependent domain. Thus, in general,  $\nabla \cdot u\mu\nabla(-\nabla \cdot \rho\nabla)^{-1}$  will be bounded on  $X$  exactly when the optimal elliptic regularity result (1.2) holds true. In that sense, wellposedness of the reduced problem (1.3) boils down exactly to the availability of the optimal regularity property (1.2) for  $q > d$ .

In the second part of the paper, we rigorously follow the above roadmap and prove local-in-time existence and uniqueness for the van Roosbroeck system for semiconductor devices using the extrapolated elliptic regularity result. The van Roosbroeck system describes the evolution of the triple  $(u_1, u_2, \varphi)$  of unknowns—representing electron- and hole densities and electrostatic potential—during the (finite) time interval  $J = (0, T)$  by the following system of coupled equations, consisting of the *Poisson equation*

$$\begin{aligned} -\operatorname{div}(\varepsilon\nabla\varphi) &= \mathfrak{d} + u_1 - u_2 && \text{in } J \times \Omega, \\ \varphi &= \varphi_D && \text{on } J \times D, \\ \nu \cdot (\varepsilon\nabla\varphi) + \varepsilon_\Gamma\varphi &= \varphi_\Gamma && \text{on } J \times \Gamma, \end{aligned} \tag{1.4a}$$

so a quasi-static elliptic equation with inhomogeneous Dirichlet and Robin boundary data, and, for  $k = 1, 2$ , the *current-continuity equations*

$$\begin{aligned} \partial_t u_k - \operatorname{div} j_k &= r^\Omega(u, \varphi) && \text{in } J \times (\Omega \setminus \Pi) \\ u_k &= U_k && \text{on } J \times D, \\ \nu \cdot j_k &= r^\Gamma(u, \varphi) && \text{on } J \times \Gamma, \\ [\nu \cdot j_k] &= r^\Pi(u, \varphi) && \text{on } J \times \Pi, \\ u_k(0) &= u_k^0 && \text{on } \Omega, \end{aligned} \tag{1.4b}$$

with the currents

$$j_k = \mu_k(\nabla u_k + (-1)^k u_k \nabla \varphi). \tag{1.4c}$$

The latter equations are nonlinear Fokker-Planck equations with inhomogeneous mixed boundary conditions and a jump condition along a surface  $\Pi \subset \Omega$ . Here,  $\Omega \subset \mathbb{R}^3$

is a bounded domain representing a semiconductor device,  $\nu$  its unit outer normal at  $\partial\Omega$  and the latter is decomposed into a Dirichlet part  $D$  and a Neumann/Robin part  $\Gamma := \partial\Omega \setminus D$ . We pose only very low regularity assumptions on the geometry of  $D, \Gamma$  and  $\Pi$  which will cover nearly all practical situations arising in realistic devices. This is made more precise in [Section 4](#) below, where the model and the involved quantities are also explained in detail. We refer to the introduction of [\[13\]](#) for a comprehensive collection of related literature. In fact, the van Roosbroeck system [\(1.4\)](#) was treated under similar assumptions recently in [\[13\]](#); however, the analysis there is quite involved since the system need be reformulated “globally” in the *quasi Fermi levels*. We are able to provide a much simpler treatment basing on the extrapolated elliptic regularity result [\(1.2\)](#) by solving [\(1.4a\)](#) for  $\varphi$  in dependence of  $u$  and inserting this dependence into [\(1.4b\)](#), thereby reducing the current-continuity equations to equations in  $u$  alone. Let us explain the principal idea and its connection to the above.

Suppose that we have formally solved [\(1.4a\)](#) for  $\varphi$  in dependence of  $u$  and consider the (reduced) *recombination* functions  $u \mapsto (r^\Omega, r^\Gamma, r^\Pi)(u, \varphi(u))$  in [\(1.4b\)](#). Then an abstract reduced formulation of [\(1.4b\)](#) would be

$$\partial_t u - \nabla \cdot \mu \nabla u = \nabla \cdot u \mu \nabla (-\nabla \cdot \varepsilon \nabla + \text{tr}_\Gamma^* \varepsilon_\Gamma \text{tr}_\Gamma)^{-1} (\mathfrak{d} + u + \text{tr}_\Gamma^* \varphi_\Gamma) + f(u) \quad (1.5)$$

where the nonlinearity  $f$  represents the reduced recombination functions,  $\text{tr}_\Gamma$  is the trace operator onto  $\Gamma$ , and we have ignored the multiple components of  $u$  and the Dirichlet boundary data in the equations for the sake of exposition at this point. This equation is of the same type as the model problem [\(1.3\)](#). In fact, it turns out that the commonly used *Avalanche generation* model for  $r^\Omega$  contained in  $f$  in [\(1.5\)](#) in a sense behaves quite similarly to the quadratic gradient nonlinearity in [\(1.5\)](#), see [Remark 4.7](#), and all the arguments from the above motivation apply. In the case of [\(1.4\)](#), we indeed need property [\(1.2\)](#) also for the second order operator including the boundary form  $\text{tr}_\Gamma^* \varepsilon_\Gamma \text{tr}_\Gamma$  corresponding to the Robin boundary conditions.

## Outline

The first part of this work first establishes the necessary groundwork for all of the following in [Section 2](#). We prove the extrapolated elliptic regularity result in full generality with lower order terms together with the necessary preparations as announced in the introduction in [Section 3](#) ([Theorem 3.9](#)). In the second part, [Section 4](#), the elliptic regularity results are then put to work for providing a proof of (local-in-time) existence and uniqueness of solutions to the Van Roosbroeck system [\(1.4\)](#) which is considerably easier than having to deal with one big macroscopic standard model for the electron/hole flux within the semiconductor as done in [\[13\]](#) ([Theorem 4.17](#)). We restrict ourselves to Boltzmann statistics. This is done only for technical simplicity, since already here all crucial effects which we want to make visible are already present. We note that one can carry out an analogous program for the quasilinear system arising in case of Fermi-Dirac statistics, see [Remark 4.18](#).

## 2 Preliminaries

All notation used in this paper is considered as standard or self-explanatory by the authors. Up to [Section 4](#), where we treat the van Rooesbroeck system (1.4), we consider a general space dimension  $d \geq 2$ . Starting from [Section 4](#), we fix  $d = 3$ .

### 2.1 Assumptions

We pose the following general assumptions on the underlying spatial domain  $\Omega \subseteq \mathbb{R}^d$  and its boundary part  $D \subseteq \partial\Omega$ . They are supposed to hold true from now on for the rest of this work. We recall the following notion, referring to e.g. [\[31\]](#):

**Definition 2.1** (Regular set). Let  $0 < N \leq d$ . The set  $\Lambda \subseteq \mathbb{R}^d$  is called *N-set* or *N-regular*, if there exist constants  $0 < c \leq C$  such that

$$cr^N \leq \mathcal{H}_N(B_r(x) \cap \Lambda) \leq Cr^N \quad (x \in \Lambda, r \in (0, 1]). \quad (2.1)$$

**Remark 2.2.** For  $N = d$ , the upper estimate requirement in (2.1) is trivial. Thus, the *interior thickness condition*, so that there exists  $\gamma > 0$  such that

$$|B_r(x) \cap \Lambda| \geq \gamma |B_r(x)| \quad (x \in \Lambda, r \in (0, 1]), \quad (\text{ICT})$$

becomes a sufficient condition for  $\Lambda$  to be *d-regular*. In fact, the interior thickness condition (ICT) can equivalently be required only for  $x \in \partial\Lambda$  ([\[5, Lem. 3.2\]](#)). In the latter form, the property is also called *d-thick* by some authors, see e.g. [\[9\]](#). There will be yet another *thickness* assumption for the treatment of the semiconductor equations in [Assumption 4.1](#).

**Assumption 2.3** (Geometry). The set  $\Omega \subset \mathbb{R}^d$  is a bounded domain satisfying the *interior thickness condition* (ICT). (Equivalently:  $\Omega$  is a *d-set*.) Moreover, the boundary  $\partial\Omega$  has the following properties:

- (i)  $D \subseteq \partial\Omega$  is a closed  $(d - 1)$ -set.
- (ii) There are Lipschitz charts available around  $\overline{\partial\Omega \setminus D}$ , that is, for every  $x \in \overline{\partial\Omega \setminus D}$ , there is an open neighborhood  $\mathcal{U}$  of  $x$  and a bi-Lipschitz mapping  $\phi_x: \mathcal{U} \rightarrow (-1, 1)^d$  such that  $\phi_x(x) = 0$  and  $\phi_x(\mathcal{U} \cap \Omega) = (-1, 0) \times (-1, 1)^{d-1}$ .

**Remark 2.4.** From  $(d - 1)$ -regularity of  $D$  and the Lipschitz charts for  $\overline{\partial\Omega \setminus D}$  we obtain that the whole boundary  $\partial\Omega$  is also a  $(d - 1)$ -set. See [\[6, Ex. 2.4/2.5\]](#).

## 2.2 Function spaces

For  $s \in \mathbb{R}$  and  $p \in (1, \infty)$ , let  $H^{s,p}(\mathbb{R}^d)$  denote the Bessel potential spaces. We mention that  $H^{-s,p'}(\mathbb{R}^d) = H^{s,p}(\mathbb{R}^d)^\star$ . We further note that for  $k \in \mathbb{N}_0$ , the classical Sobolev space of  $k$ th order  $W^{k,p}(\mathbb{R}^d)$  coincides with  $H^{k,p}(\mathbb{R}^d)$  up to equivalent norms. See e.g. [58, Ch. 2.3.3&2.6.1].

**Definition 2.5** (Sobolev-Slobodetskii spaces). Let  $p \in (1, \infty)$  and  $s > 0$  not an integer. Write  $s = k + \sigma$  with  $k \in \mathbb{N}_0$  and  $\sigma \in (0, 1)$ . Then the space  $W^{s,p}(\mathbb{R}^d)$  is given by the normed vector space of functions  $u \in L^p(\mathbb{R}^d)$  for which

$$\|u\|_{W^{s,p}(\mathbb{R}^d)} := \|u\|_{W^{k,p}(\mathbb{R}^d)} + \left( \sum_{i=1}^d \iint_{\mathbb{R}^d \times \mathbb{R}^d} \frac{|\partial_i^k u(x) - \partial_i^k u(y)|^p}{|x - y|^{d+\sigma p}} dx dy \right)^{1/p} < \infty.$$

Moreover, we define  $W^{-s,p'}(\mathbb{R}^d) := W^{s,p}(\mathbb{R}^d)^\star$ , the space of antilinear continuous functionals on  $W^{s,p}(\mathbb{R}^d)$ .

Let  $X \in \{H, W\}$  for the remainder of this section. We next turn to traces.

**Proposition 2.6** ([31, Thms. VI.1&VII.1]). Let  $E \subset \mathbb{R}^d$  be a  $(d-1)$ -set and let  $s \in (\frac{1}{p}, 1 + \frac{1}{p})$  with  $p \in (1, \infty)$ . Then the trace operator  $\text{tr}_E$  defined by

$$(\text{tr}_E u)(x) := \lim_{r \searrow 0} \frac{1}{|B_r(x)|} \int_{B_r(x)} u \quad (x \in E)$$

maps  $X^{s,p}(\mathbb{R}^d)$  continuously into  $L^p(E; \mathcal{H}_{d-1})$ .

**Definition 2.7** (Function spaces with zero trace). Let  $E \subset \mathbb{R}^d$  be a  $(d-1)$ -set and let  $s \in (\frac{1}{p}, 1 + \frac{1}{p})$  with  $p \in (1, \infty)$ . Then we define  $X_E^{s,p}(\mathbb{R}^d) := \ker \text{tr}_E$  in  $X^{s,p}(\mathbb{R}^d)$ .

The versions of the spaces  $X^{s,p}$  and  $X_E^{s,p}$  on  $\Omega$  are defined as quotient spaces corresponding to restriction to  $\Omega$  of their  $\mathbb{R}^d$  versions as follows:

**Definition 2.8** (Function spaces on  $\Omega$ ). Let  $p \in (1, \infty)$  and  $s > 0$ .

- (i) We define  $X^{s,p}(\Omega)$  to be the factor space of restrictions to  $\Omega$  of  $X^{s,p}(\mathbb{R}^d)$ , equipped with the natural quotient norm. Moreover,  $X^{-s,p'}(\Omega) := X^{s,p}(\Omega)^\star$ .
- (ii) Let now  $s \in (\frac{1}{p}, 1 + \frac{1}{p})$  and let  $E \subseteq \overline{\Omega}$  be a  $(d-1)$ -set. Then, as before, we define  $X_E^{s,p}(\Omega)$  to be the factor space of restrictions to  $\Omega$  of  $X_E^{s,p}(\mathbb{R}^d)$ , equipped with the natural quotient norm. Moreover,  $X_E^{-s,p'}(\Omega) := X_E^{s,p}(\Omega)^\star$ .

**Remark 2.9.** The definition of the spaces  $X^{s,p}(\Omega)$  as factor spaces of restrictions implies that these spaces inherit the usual Sobolev-type embeddings between them from their full-space analogues.

**Remark 2.10.** Let  $s \in (0, 1)$ . Then it is well known that since  $\Omega$  satisfies (ICT), the factor space  $W^{s,p}(\Omega)$  agrees with the space  $W_*^{s,p}(\Omega)$  defined intrinsically by the set of all functions  $u \in L^p(\Omega)$  such that

$$\|u\|_{W_*^{s,p}(\Omega)} := \|u\|_{L^p(\Omega)} + \left( \iint_{\Omega \times \Omega} \frac{|u(x) - u(y)|^p}{|x - y|^{d+sp}} dx dy \right)^{1/p} < \infty$$

up to equivalent norms. (See [31, Thm. V.1]). Moreover, very recently it was shown in [5] that if  $E \subseteq \partial\Omega$  is  $(d-1)$ -regular and  $\Omega$  satisfies the interior thickness condition (ICT) for  $x \in \partial\Omega \setminus E$ , then  $W_E^{s,p}(\Omega)$  coincides with the intrinsically given  $W_*^{s,p}(\Omega) \cap L^p(\Omega, \text{dist}_E^{-sp})$ , also up to equivalent norms.

We next quote interpolation results from [6] for *symmetric* interpolation where both involved spaces carry partially vanishing trace. This result and its dual variant below will be used for the extrapolated elliptic regularity result in Section 3.

**Proposition 2.11** (Interpolation [6, Thm. 1.2]). *Let  $p_i \in (1, \infty)$  and  $s_i \in (\frac{1}{p_i}, 1 + \frac{1}{p_i})$  for  $i = 1, 2$ . Set  $\frac{1}{p_\theta} = \frac{1-\theta}{p_0} + \frac{\theta}{p_1}$  and  $s_\theta = (1-\theta)s_0 + \theta s_1$ . Let further  $E \subseteq \bar{\Omega}$  be a  $(d-1)$ -set. Then, up to equivalent norms, we have*

$$[X_E^{s_0, p_0}(\Omega), X_E^{s_1, p_1}(\Omega)]_\theta = X_E^{s_\theta, p_\theta}(\Omega) \quad (2.2)$$

and

$$(X_E^{s_0, p_0}(\Omega), X_E^{s_1, p_1}(\Omega))_{\theta, p_\theta} = W_E^{s_\theta, p_\theta}(\Omega), \quad (2.3)$$

with the following exceptions: if  $s_\theta = 1$  in (2.3), then we must already have  $s_0 = s_1 = 1$ ; moreover,  $X = W$  is permitted in (2.2) only if either all or none of  $s_0, s_1, s_\theta$  are 1.

**Corollary 2.12.** *Adopt the assumptions of Proposition 2.11. Then, up to equivalent norms, we have*

$$[X_E^{-s_0, p_0}(\Omega), X_E^{-s_1, p_1}(\Omega)]_\theta = X_E^{-s_\theta, p_\theta}(\Omega)$$

and

$$(X_E^{-s_0, p_0}(\Omega), X_E^{-s_1, p_1}(\Omega))_{\theta, p_\theta} = W_E^{-s_\theta, p_\theta}(\Omega),$$

with the exceptions as in Proposition 2.11.

*Proof.* The assertions follow from the corresponding ones in Proposition 2.11 by general duality properties of the interpolation functors, see e.g. [58, Ch. 1.11.3]. Before we validate the assumptions there, let us note that the present corollary is an assertion about *anti-dual* spaces, whereas the cited result is about ordinary dual spaces. However, we



can recover the anti-dual case from the dual one by means of the retraction-coretraction theorem ([58, Ch. 1.2.4]) using the mapping  $\psi \mapsto [f \mapsto \langle \psi, \bar{f} \rangle]$  both as the retraction and coretraction between anti-dual and dual space.

Now let us turn to the assumptions in [58, Ch. 1.11.3]: First,  $X_E^{s_0, p_0}(\Omega) \cap X_E^{s_1, p_1}(\Omega)$  is dense in  $X_E^{s_i, p_i}(\Omega)$  for  $i = 1, 2$ . This can be seen as follows: For all  $p \in (1, \infty)$  and  $s \in (\frac{1}{p}, 1 + \frac{1}{p})$ , the spaces  $X_E^{s, p}(\mathbb{R}^d)$  are complemented subspaces of  $X^{s, p}(\mathbb{R}^d)$  by virtue of a  $(s, p)$ -uniform projection  $\mathcal{P}$  as shown in [6, Lem. 3.1]. But  $X^{s_0, p_0}(\mathbb{R}^d) \cap X^{s_1, p_1}(\mathbb{R}^d)$  is dense in  $X^{s_i, p_i}(\mathbb{R}^d)$ , hence  $\mathcal{P}(X^{s_0, p_0}(\mathbb{R}^d) \cap X^{s_1, p_1}(\mathbb{R}^d)) = X_E^{s_0, p_0}(\mathbb{R}^d) \cap X_E^{s_1, p_1}(\mathbb{R}^d)$  is dense in  $X_E^{s_i, p_i}(\mathbb{R}^d)$ . This then immediately transfers to density of  $X_E^{s_0, p_0}(\Omega) \cap X_E^{s_1, p_1}(\Omega)$  in  $X_E^{s_i, p_i}(\Omega)$ .

Moreover, the spaces  $X_E^{s_i, p_i}(\Omega)$  are reflexive: They are factor spaces of  $X_E^{s_i, p_i}(\mathbb{R}^d)$  which are reflexive because they are complemented subspaces of the reflexive spaces  $X^{s_i, p_i}(\mathbb{R}^d)$  as already seen above.  $\square$

### 2.3 Operators

Finally, let us define the elliptic operators in divergence form and associated operators. We first establish the usual intrinsic norm on  $W_D^{1, p}(\Omega)$ , which so far only carries the abstract quotient norm inherited from  $W_D^{1, p}(\mathbb{R}^d)$ . For  $E \subset \mathbb{R}^d$ , let us define

$$C_E^\infty(\mathbb{R}^d) := \left\{ f \in C_c^\infty(\mathbb{R}^d) : \text{dist}(\text{supp } f, E) > 0 \right\}, \quad \text{and} \quad C_E^\infty(\Omega) := C_E^\infty(\mathbb{R}^d)|_\Omega.$$

**Lemma 2.13** ([6, Prop. B.3]). *Let  $p \in (1, \infty)$ . Then*

$$\|f\|_{W^{1, p}(\Omega)}^* := \left( \|f\|_{L^p(\Omega)}^p + \|\nabla f\|_{L^p(\Omega)}^p \right)^{\frac{1}{p}}$$

*is an equivalent, intrinsic norm on  $W_D^{1, p}(\Omega)$ . In fact,  $W_D^{1, p}(\Omega)$  is the closure of  $C_D^\infty(\Omega)$  in this norm.*

**Definition 2.14** (Coefficient functions). Let  $0 < \rho_\bullet \leq \rho^\bullet$  be given. We define  $\mathcal{C}(\rho_\bullet, \rho^\bullet)$  to be the set of all measurable functions  $\rho: \Omega \rightarrow \mathbb{C}^{d \times d}$  such that

$\text{Re } \xi^H \rho(x) \xi \geq \rho_\bullet \|\xi\|_2$  and  $\|\rho(x)\|_{\mathcal{L}(\mathbb{C}^d \rightarrow \mathbb{C}^d)} \leq \rho^\bullet$  hold true for almost all  $x \in \Omega$  and all  $\xi \in \mathbb{C}^d$ .

From now on, whenever we refer to  $\mathcal{C}(a, b)$  we tacitly assume  $0 < a \leq b$ .

**Definition 2.15** (Second-order elliptic operator in divergence form). Let  $\rho \in \mathcal{C}(\rho_\bullet, \rho^\bullet)$ . We define the second-order operator  $-\nabla \cdot \rho \nabla$  by

$$\langle -\nabla \cdot \rho \nabla u, v \rangle := \int_\Omega \rho \nabla u \cdot \overline{\nabla v}.$$

By the assumption on  $\rho$ , it is clear that  $-\nabla \cdot \rho \nabla \in \mathcal{L}(W_D^{1,p}(\Omega) \rightarrow W_D^{-1,p}(\Omega))$  for all  $p \in (1, \infty)$ , with the operator norm bounded by  $\rho^\bullet$ .

**Remark 2.16.** (i) For  $p = 2$ , based on [Lemma 2.13](#), the Lax-Milgram lemma implies that  $-\nabla \cdot \rho \nabla$  is continuously invertible whenever  $\mathbf{1} \notin W_D^{1,2}(\Omega)$ , and in this case the norm of the inverse is bounded by  $\rho_\bullet^{-1}$ .

(ii) In connection with the previous point and the introduction with the elliptic regularity property [\(1.1\)](#), let us point out that  $-\nabla \cdot \rho \nabla$  will in general *not* be surjective as an operator  $W_D^{1,p}(\Omega) \rightarrow W_D^{-1,p}(\Omega)$  for  $p \neq 2$ , even if  $\mathbf{1} \notin W_D^{1,p}(\Omega)$ . This is why often the maximal co-restriction to, say,  $W_D^{-1,p}(\Omega)$  for  $p > 2$  of  $-\nabla \cdot \rho \nabla: W_D^{1,2}(\Omega) \rightarrow W_D^{-1,2}(\Omega)$  is considered, as an unbounded operator in  $W_D^{-1,p}(\Omega)$ . We will however not need this distinction for this work.

**Definition 2.17** (First-order operators). Let  $\beta \in L^\infty(\Omega; \mathbb{C}^d)$ . We define the first-order operators  $-\nabla \cdot \beta$  and  $\beta \cdot \nabla$  by

$$\langle -\nabla \cdot \beta u, v \rangle := \int_{\Omega} u \beta \cdot \overline{\nabla v} \quad \text{and} \quad \langle \beta \cdot \nabla u, v \rangle := \int_{\Omega} \beta \cdot \nabla u \bar{v}.$$

The operators give rise to continuous linear operators  $W_D^{1,p}(\Omega) \rightarrow W_D^{-1,p}(\Omega)$  for every  $p \in (1, \infty)$ . This follows via Sobolev embedding.

We next introduce a suitable trace operator for functions in  $W^{s,p}(\Omega)$ .

**Lemma 2.18** ([\[9, Thm. 8.7 \(iii\)\]](#)). *Let  $p \in (1, \infty)$  and  $s \in (\frac{1}{p}, 1 + \frac{1}{p})$ . Let  $E \subseteq \overline{\Omega}$  be a  $(d-1)$ -set and consider  $u \in W^{s,p}(\Omega)$ . Then the inner trace  $\text{i-tr}_E u$  given by*

$$(\text{i-tr}_E u)(x) := \lim_{r \searrow 0} \frac{1}{|B_r(x) \cap \Omega|} \int_{B_r(x) \cap \Omega} u \quad (x \in E)$$

*is well defined and coincides with the trace of any  $W^{s,p}(\mathbb{R}^d)$ -extension of  $u$ , that is,  $\text{i-tr}_E u = \text{tr}_E \hat{u}$  for all  $\hat{u} \in W^{s,p}(\mathbb{R}^d)$  such that  $\hat{u}|_{\Omega} = u$ .*

We refer to [Remark 2.2](#) regarding the assumption *d-thick* in [\[9\]](#). In view of the foregoing [Lemma 2.18](#), there will be no ambiguity if we use the notation  $\text{tr}_E$  also for the interior trace operator on  $W^{s,p}(\Omega)$ . We thus do so from now on.

**Corollary 2.19.** *Let  $p \in (1, \infty)$  and  $s > \frac{1}{p}$ . Let  $E \subseteq \overline{\Omega}$  be a  $(d-1)$ -set.*

1. *Let  $sp < d$  and  $s + \frac{d-1}{q} = \frac{d}{p}$ . Then  $\text{tr}_E: W^{s,p}(\Omega) \rightarrow L^r(E; \mathcal{H}_{d-1})$  is continuous for  $r = q$  and even compact for  $r \in [1, q)$ .*
2. *Let  $sp > d$ . Then  $\text{tr}_E: W^{s,p}(\Omega) \rightarrow L^\infty(E; \mathcal{H}_{d-1})$  is compact.*

*Proof.* There is a continuous extension operator  $W^{s,p}(\Omega) \rightarrow W^{s,p}(\mathbb{R}^d)$  by [31, Thm. VI.1] since  $\Omega$  is a  $d$ -set by assumption; cf. also Remark 2.10. It is sufficient to establish the claims for  $s \in (\frac{1}{p}, 1 + \frac{1}{p})$  due to Sobolev embedding. Thus, we can rely on Lemma 2.18 to derive the desired properties from the trace operator on the full space in this case.

- (i) It is sufficient to establish the continuity assertion for  $r = q$ . To this end, we combine [7, Thm. 6.8] with [31, Thm. V.1] applied to  $E$ . This shows that  $\text{tr}_E: W^{s,p}(\mathbb{R}^d) \rightarrow L^q(E; \mathcal{H}_{d-1})$  is continuous. Regarding compactness, let us note that if  $r \in [1, q)$ , then  $s + \frac{d-1}{r} > \frac{d}{p}$ , hence  $(\frac{d-1}{r} - \frac{d}{p}, s) \neq \emptyset$ . Choosing  $\alpha$  from that interval, we have  $W^{s,p}(\mathbb{R}^d) \hookrightarrow H^{\alpha,p}(\mathbb{R}^d)$  by classical embeddings. Now the proof of [7, Cor. 7.3] applies *mutatis mutandis*.
- (ii) In this case, every function from  $W^{s,p}(\mathbb{R}^d)$  admits a Hölder continuous bounded representative by classical Sobolev embedding. The assertion follows from the Arzelà-Ascoli theorem. □

With the foregoing Corollary 2.19, the following is well defined:

**Definition 2.20.** Let  $E \subseteq \bar{\Omega}$  be a  $(d-1)$ -set and let  $\varrho \in L^\infty(E; \mathcal{H}_{d-1})$ . We define

$$\langle \text{tr}_E^* \varrho \text{tr}_E u, v \rangle := \int_E \varrho (\text{tr}_E u) \overline{(\text{tr}_E v)} \, d\mathcal{H}_{d-1}.$$

The operators  $\text{tr}_E^* \varrho \text{tr}_E$  define continuous linear operators  $W_D^{1,p}(\Omega) \rightarrow W_D^{-1,p}(\Omega)$  for every  $p \in (1, \infty)$ .

We next put all the above defined operators to work for our main result.

### 3 Extrapolation of elliptic regularity

In this section, we establish the main result, Theorem 3.9. We first quote the Sneiberg theorem in a quantitative version from [3, Appendix]. It is the abstract result which will allow us to extrapolate the isomorphism property.

**Theorem 3.1** (Quantitative Sneiberg). *Let  $(X_0, X_1)$  and  $(Y_0, Y_1)$  be interpolation couples of Banach spaces, and let  $A$  be a continuous linear operator satisfying  $A \in \mathcal{L}(X_0 \rightarrow Y_0) \cap \mathcal{L}(X_1 \rightarrow Y_1)$ . Then the set*

$$\mathcal{I}(A) := \left\{ \theta \in (0, 1) : A \in \mathcal{L}_{\text{iso}}([X_0, Y_0]_\theta \rightarrow [X_1, Y_1]_\theta) \right\}$$

*is an open interval. In fact, suppose that  $\bar{\theta} \in \mathcal{I}(A)$  and consider  $\kappa > 0$  such that*

$$\|Ax\|_{[X_1, Y_1]_{\bar{\theta}}} \geq \kappa \|x\|_{[X_0, Y_0]_{\bar{\theta}}} \quad \text{for all } x \in [X_0, Y_0]_{\bar{\theta}}.$$

Then

$$|\theta - \bar{\theta}| \leq \frac{\kappa \max(\bar{\theta}, 1 - \bar{\theta})}{6\kappa + 12 \max(\|A\|_{\mathcal{L}(X_0; Y_0)}, \|A\|_{\mathcal{L}(X_1; Y_1)})} \quad (3.1)$$

implies that  $\theta \in \mathcal{I}(A)$  with  $\|A^{-1}\|_{[X_1, Y_1]_\theta \rightarrow [X_0, Y_0]_\theta} \leq 8\kappa^{-1}$ .

Of course,  $\mathcal{I}(A)$  in [Theorem 3.1](#) can be empty. Since the Slobotetskii scale is obtained by *real* interpolation, see [\(2.3\)](#), we also give the following corollary to [Theorem 3.1](#) considering the real interpolation scale.

**Corollary 3.2.** *Adopt the setting of [Theorem 3.1](#). Then*

$$\mathcal{I}(A) \subseteq \left\{ \theta \in (0, 1) : A \in \mathcal{L}_{\text{iso}}((X_0, Y_0)_{\theta, q} \rightarrow (X_1, Y_1)_{\theta, q}) \right\}$$

for all  $q \in [1, \infty]$ .

*Proof.* Let  $\theta \in \mathcal{I}(A)$ . Since  $\mathcal{I}(A)$  is open by [Theorem 3.1](#), we can choose  $\tau, \sigma \in \mathcal{I}(A)$  and  $\lambda \in (0, 1)$  such that  $\theta = (1 - \lambda)\tau + \lambda\sigma$ . Then

$$A: ([X_0, X_1]_\tau, [X_0, X_1]_\sigma)_{\lambda, q} \rightarrow ([Y_0, Y_1]_\tau, [Y_0, Y_1]_\sigma)_{\lambda, q}$$

remains continuously invertible for all  $q \in [1, \infty]$ . But, by re-iteration, the space on the left hand side is  $(X_0, X_1)_{(1-\lambda)\tau + \lambda\sigma, q} = (X_0, X_1)_{\theta, q}$ , and the one on the right hand side is  $(Y_0, Y_1)_{(1-\lambda)\tau + \lambda\sigma, q} = (Y_0, Y_1)_{\theta, q}$ , cf. [\[58, Thm. 1.10.3.2\]](#).  $\square$

Our next intermediate goal is to extend the gradient  $\nabla: H^{1,p}(\Omega) \rightarrow L^p(\Omega)^d$  continuously to a mapping  $H^{1-s,p}(\Omega) \rightarrow H^{-s,p}(\Omega)^d$ . This will then allow to also extend the elliptic operator  $-\nabla \cdot \rho \nabla$ , cf. [Lemma 3.7](#) below. To this end, we first quote the following result regarding continuity of the zero extension in the low regularity regime. (See [Remark 2.4](#) to validate its assumptions.)

**Lemma 3.3** ([\[6, Cor. 2.18\]](#)). *Let  $p \in (1, \infty)$  and  $s \in [0, \frac{1}{p})$ . Then zero extension*

$$(\mathcal{E}_0 f)(x) = \begin{cases} f(x) & \text{if } x \in \Omega, \\ 0 & \text{otherwise} \end{cases}$$

is a continuous linear operator  $\mathcal{E}_0: X^{s,p}(\Omega) \rightarrow X^{s,p}(\mathbb{R}^d)$  for both  $X = H$  or  $W$ .

**Lemma 3.4.** *Let  $p \in (1, \infty)$  and  $s \in [0, \frac{1}{p})$ . Then  $C_{\partial\Omega}^\infty(\Omega)$  is dense in  $H^{s,p}(\Omega)$ .*

*Proof.* It is enough to show that  $H^{s,p}(\Omega)$  is a subset of the closure  $H_0^{s,p}(\Omega)$  of  $C_{\partial\Omega}^\infty(\Omega)$  in the  $H^{s,p}(\Omega)$  norm. Let  $f \in H^{s,p}(\Omega)$ . [Lemma 3.3](#) asserts that  $\mathcal{E}_0 f \in H^{s,p}(\mathbb{R}^d)$ . Clearly,  $\mathcal{E}_0 f = 0$  on  $\mathbb{R}^d \setminus \Omega$ . A theorem of Netrusov ([\[1, Thm. 10.1.1\]](#)) thus implies that  $f \in H_0^{s,p}(\Omega)$ .  $\square$

**Lemma 3.5.** *Let  $p \in (1, \infty)$  and  $s \in (0, \frac{1}{p} \wedge \frac{1}{p'})$ . Then the weak gradient  $\nabla \in \mathcal{L}(H^{1,p}(\Omega) \rightarrow L^p(\Omega)^d)$  maps  $H^{1+s,p}(\Omega)$  continuously nonexpansively into  $H^{s,p}(\Omega)^d$  and admits a unique continuous linear and still nonexpansive extension to a mapping  $\nabla: H^{1-s,p}(\Omega) \rightarrow H^{-s,p}(\Omega)^d$ .*

*Proof.* The proof is based on the observation that the distributional (partial) derivative  $\partial_j$ ,  $j \in \{1, \dots, d\}$ , is a continuous linear contraction from  $H^{\sigma,q}(\mathbb{R}^d)$  to  $H^{\sigma-1,q}(\mathbb{R}^d)$  for all  $\sigma \in \mathbb{R}$  and all  $q \in (1, \infty)$ . This in turn can be seen e.g. for  $\sigma$  an integer via  $H^{k,q}(\mathbb{R}^d) = W^{k,q}(\mathbb{R}^d)$  for  $k \in \mathbb{N}_0$  and a duality argument; the general case for  $\sigma$  then follows by interpolation. Moreover, this distributional derivative is of course consistent with the weak derivative on  $H^{1,q}(\mathbb{R}^d)$ .

The first claim thus follows immediately from the definitions of  $H^{1+s,p}(\Omega)$  and  $H^{s,p}(\Omega)$  as the restrictions of the corresponding spaces on  $\mathbb{R}^d$ . For the second one, consider  $f \in H^{1-s,p}(\Omega)$  and let  $\widehat{f} \in H^{1-s,p}(\mathbb{R}^d)$  be such that  $\widehat{f}|_{\Omega} = f$ . Let moreover  $\varphi \in C_{\partial\Omega}^{\infty}(\Omega)$  and identify it with its extension by zero  $\mathcal{E}_0\varphi$  to  $\mathbb{R}^d$ . Then  $\mathcal{E}_0\varphi \in H^{s,p'}(\mathbb{R}^d)$  by Lemma 3.3 and in fact  $\|\varphi\|_{H^{s,p'}(\Omega)} = \|\mathcal{E}_0\varphi\|_{H^{s,p'}(\mathbb{R}^d)}$ . Let  $j \in \{1, \dots, d\}$ . We observe that

$$\langle \partial_j f, \varphi \rangle := - \int_{\Omega} f \partial_j \varphi = - \int_{\mathbb{R}^d} \widehat{f} \partial_j \mathcal{E}_0 \varphi,$$

hence

$$\begin{aligned} |\langle \partial_j f, \varphi \rangle| &\leq \|\widehat{f}\|_{H^{1-s,p}(\mathbb{R}^d)} \|\partial_j \mathcal{E}_0 \varphi\|_{H^{s-1,p'}(\mathbb{R}^d)} \\ &\leq \|\widehat{f}\|_{H^{1-s,p}(\mathbb{R}^d)} \|\mathcal{E}_0 \varphi\|_{H^{s,p'}(\mathbb{R}^d)} = \|\widehat{f}\|_{H^{1-s,p}(\mathbb{R}^d)} \|\varphi\|_{H^{s,p'}(\Omega)}. \end{aligned}$$

Note that  $C_{\partial\Omega}^{\infty}(\Omega)$  is dense in  $H^{s,p'}(\Omega)$  since  $s \in [0, 1 - \frac{1}{p})$ , cf. Lemma 3.4. Thus, taking the infimum over all  $\widehat{f} \in H^{1-s,p}(\mathbb{R}^d)$  such that  $\widehat{f}|_{\Omega} = f$ , we find  $\partial_j \in \mathcal{L}(H^{1-s,p}(\Omega) \rightarrow H^{-s,p}(\Omega))$ , since  $H^{-s,p}(\Omega) = (H^{s,p'}(\Omega))^*$  by definition.  $\square$

We also need the notion of a *multiplier*.

**Definition 3.6** (Multiplier). Let  $X$  be a Banach space of functions  $\Omega \rightarrow \mathbb{C}$ .

- (i) A function  $\omega: \Omega \rightarrow \mathbb{C}$  is a *multiplier on  $X$*  if the superposition operator  $M_{\omega}$  defined by  $(M_{\omega}f)(x) := \omega(x)f(x)$  maps  $X$  continuously into itself. We write  $\omega \in \mathcal{M}(X)$  and the multiplier norm is given by  $\|\omega\|_{\mathcal{M}(X)} := \|M_{\omega}\|_{X \rightarrow X}$ .
- (ii) For a matrix function  $\omega: \Omega \rightarrow \mathbb{C}^{d \times d}$  where each component satisfies  $\omega_{ij} \in \mathcal{M}(X)$ , we use the associated *multiplier norm* defined by

$$\|\omega\|_{\mathcal{M}(X)} = \sqrt{\sum_{i=1}^m \sum_{j=1}^n \|\omega_{ij}\|_{\mathcal{M}(X)}^2}.$$

Using multiplier assumptions, all of the differential and boundary operators introduced in [Section 2.3](#) can be extended to the Bessel scale. The collected result is as follows:

**Lemma 3.7.** *Let  $p \in (1, \infty)$  and  $\tau \in (0, \frac{1}{p} \wedge \frac{1}{p'})$ , and let moreover the following assumptions be satisfied:*

- $\rho: \Omega \rightarrow \mathbb{C}^{d \times d}$  such that  $\rho_{ij} \in \mathcal{M}(H^{\tau,p}(\Omega)) \cap \mathcal{M}(H^{\tau,p'}(\Omega))$ ,
- $\beta_{\text{div}}, \beta_g \in \mathcal{M}(H^{\tau,p}(\Omega))^d \cap \mathcal{M}(H^{\tau,p'}(\Omega))^d$ ,
- $\eta \in L^d(\Omega)$ ,
- $E \subseteq \bar{\Omega}$  is a  $(d-1)$ -set and  $\varrho \in L^\infty(E; \mathcal{H}_{d-1})$ .

Then the operator  $A$  defined by

$$A := -\nabla \cdot \rho \nabla - \nabla \cdot \beta_{\text{div}} + \beta_g \cdot \nabla + \eta + \text{tr}_E^* \varrho \text{tr}_E \quad (3.2)$$

maps  $H_D^{1+\tau,p}(\Omega)$  continuously into  $H_D^{\tau-1,p}(\Omega)$ , and linearly extends to a continuous mapping from  $H_D^{1-\tau,p}(\Omega)$  to  $H_D^{-1-\tau,p}(\Omega)$ .

*Proof.* We first show that  $-\nabla \cdot \rho \nabla$  maps  $H_D^{1+\tau,p}(\Omega)$  continuously into  $H_D^{\tau-1,p}(\Omega)$  using the multiplier assumption. So, let  $\varphi \in H_D^{1+\tau,p}(\Omega)$  and  $\psi \in W_D^{1,p'}(\Omega)$ . Then  $\nabla \psi \in L^{p'}(\Omega) \subset H_D^{-\tau,p}(\Omega)$ , and using [Lemma 3.5](#), we find

$$\begin{aligned} \langle -\nabla \cdot \rho \nabla \varphi, \psi \rangle &= (\rho \nabla \varphi, \nabla \psi)_{L^2(\Omega)^d} \leq \|\rho\|_{\mathcal{M}(H^{\tau,p}(\Omega))} \|\nabla \varphi\|_{H^{\tau,p}(\Omega)^d} \|\nabla \psi\|_{H^{-\tau,p'}(\Omega)^d} \\ &\leq \|\rho\|_{\mathcal{M}(H^{\tau,p}(\Omega))} \|\varphi\|_{H_D^{1+\tau,p}(\Omega)} \|\psi\|_{H_D^{1-\tau,p'}(\Omega)}. \end{aligned}$$

Since  $W_D^{1,p'}(\mathbb{R}^d)$  is dense in  $H_D^{1-\tau,p'}(\mathbb{R}^d)$ , so is  $W_D^{1,p'}(\Omega)$  in  $H_D^{1-\tau,p'}(\Omega)$ . Accordingly,  $-\nabla \cdot \rho \nabla$  maps  $H_D^{1+\tau,p}(\Omega)$  continuously into  $H_D^{\tau-1,p}(\Omega)$ .

Next, we show that  $-\nabla \cdot \rho \nabla$  continuously extends to an operator from  $H_D^{1-\tau,p}(\Omega)$  to  $H_D^{-1-\tau,p}(\Omega)$ . We follow the same reasoning as above, this time for  $\varphi \in W_D^{1,p}(\Omega)$  and  $\psi \in H_D^{1+\tau,p'}(\Omega)$ , to obtain

$$\langle -\nabla \cdot \rho \nabla \varphi, \psi \rangle = (\nabla \varphi, \rho^H \nabla \psi)_{L^2(\Omega)^d} \leq \|\rho^H\|_{\mathcal{M}(H^{\tau,p'}(\Omega))} \|\varphi\|_{H_D^{1-\tau,p}(\Omega)} \|\psi\|_{H_D^{1+\tau,p'}(\Omega)}.$$

Density of  $W_D^{1,p}(\Omega)$  in  $H_D^{1-\tau,p}(\Omega)$  then yields that  $-\nabla \cdot \rho \nabla$  extends continuously to  $H_D^{1-\tau,p}(\Omega)$ , mapping into  $H_D^{-1-\tau,p}(\Omega)$ .

The first-order operators  $\nabla \cdot \beta_{\text{div}}$  and  $\beta_g \cdot \nabla$  work exactly analogously. For the zero-order operator, the claim follows from Sobolev embeddings and Hölder's inequality. Let us

thus turn to the boundary form operator. Choose  $s \in (\tau, \frac{1}{p} \wedge \frac{1}{p'})$ . Letting  $u \in H_D^{1+\tau,p}(\Omega)$  and  $v \in H_D^{1+\tau,p'}(\Omega)$ , we estimate easily via [Corollary 2.19](#):

$$\begin{aligned} \langle \mathrm{tr}_E^* \varrho \mathrm{tr}_E u, v \rangle &\leq \|\varrho\|_{L^\infty(E; \mathcal{H}_{d-1})} \|\mathrm{tr}_E u\|_{L^p(E; \mathcal{H}_{d-1})} \|\mathrm{tr}_E v\|_{L^{p'}(E; \mathcal{H}_{d-1})} \\ &\lesssim \|\varrho\|_{L^\infty(E; \mathcal{H}_{d-1})} \|u\|_{W^{1-s,p}(\Omega)} \|v\|_{W^{1-s,p'}(\Omega)}. \end{aligned} \quad (3.3)$$

Now the assertion follows from the embeddings ([\[58, Thm. 4.6.1\]](#))

$$H_D^{1+\tau,p}(\Omega) \hookrightarrow H_D^{1-\tau,p}(\Omega) \hookrightarrow W^{1-s,p}(\Omega), \quad H_D^{1+\tau,p'}(\Omega) \hookrightarrow H_D^{1-\tau,p'}(\Omega) \hookrightarrow W^{1-s,p'}(\Omega),$$

where the first ones in the respective chain are dense.  $\square$

**Remark 3.8.** Let  $p \in (1, \infty)$  and  $\tau \in (0, \frac{1}{p})$ .

- (i) All multipliers considered will be bounded:  $\mathcal{M}(H^{\tau,p}(\Omega)) \hookrightarrow \mathcal{M}(L^p(\Omega))$  and  $L^\infty(\Omega) = \mathcal{M}(L^p(\Omega))$ , the latter up to equivalent norms. Indeed, note that the constant function  $\mathbf{1}$  is an element of  $H^{\tau,p}(\Omega)$ . So let  $k \in \mathbb{N}$  and consider for  $\omega \in \mathcal{M}(H^{\tau,p}(\Omega))$ :

$$\|\omega\|_{L^{pk}(\Omega)} = \|\omega^k \mathbf{1}\|_{L^p(\Omega)}^{\frac{1}{k}} \lesssim \|\omega^k \mathbf{1}\|_{H^{\tau,p}(\Omega)}^{\frac{1}{k}} \lesssim \|\omega\|_{\mathcal{M}(H^{\tau,p}(\Omega))} \|\mathbf{1}\|_{H^{\tau,p}(\Omega)}^{\frac{1}{k}}.$$

Since  $\|\mathbf{1}\|_{H^{\tau,p}(\Omega)}^{\frac{1}{k}} \lesssim 1$ , the desired embedding follows by letting  $k \rightarrow \infty$ . It is easy to see that  $L^\infty(\Omega)$  and  $\mathcal{M}(L^p(\Omega))$  are isomorphic. Note moreover that  $\mathcal{M}(H^{\tau,p}(\Omega)) \hookrightarrow \mathcal{M}(L^p(\Omega))$  implies that  $\mathcal{M}(H^{\tau,p}(\Omega)) \hookrightarrow \mathcal{M}(H^{\sigma,p}(\Omega))$  for all  $\sigma \in [0, \tau]$  via complex interpolation ([\[6, Rem. 3.9\]](#)).

- (ii) We do not have a general description of  $\mathcal{M}(H^{\tau,p}(\Omega))$  for  $\tau > 0$  in terms of classical function spaces. However, there is a substantial body of work devoted to multipliers on the usual function spaces; we mention exemplarily the comprehensive books [\[38, 51\]](#), or [\[37, Sect. 5\]](#). We give a few examples. Most generally, due to the condition  $\tau < \frac{1}{p}$ , [Lemma 3.3](#) implies that  $\mathcal{M}(H^{\tau,p}(\mathbb{R}^d)) \hookrightarrow \mathcal{M}(H^{\tau,p}(\Omega))$ . It is moreover a classical result that  $C^\sigma(\Omega) \hookrightarrow \mathcal{M}(H^{\tau,p}(\Omega))$  whenever  $\tau < \sigma \leq 1$ , where  $C^\sigma(\Omega)$  denotes the space of  $\sigma$ -Hölder continuous functions. In fact, already a slightly larger Besov space does the job:  $B_{\infty,p}^\tau(\Omega) \hookrightarrow \mathcal{M}(H^{\tau,p}(\Omega))$ . We refer to e.g. [\[51, Ch. 4.7.1\]](#) and [\[27, Lem. 1\]](#), where it is also mentioned that  $B_{\infty,p}^\tau(\Omega) \hookrightarrow C^\tau(\Omega)$ . But continuity is not at all necessary for the multiplier property, in particular in the present low-regularity case of  $\tau < \frac{1}{p}$ : already the characteristic functions  $\chi_\Lambda$  of certain subsets  $\Lambda \subset \Omega$  are also multipliers on  $H^{\tau,p}(\Omega)$ . Examples for sets  $\Lambda$  with this property are convex sets ([\[38, Rem. 3.5.3\]](#)) or sets of locally finite perimeter ([\[51, p. 214ff\]](#)); see also [\[54\]](#) for the probably most general admissible class. (In fact, [\[54, Thm. 4.4\]](#) provides [Lemma 3.3](#).)

The following is our main result for this section. It holds for both  $X \in \{H, W\}$ .

**Theorem 3.9.** *Let  $p \in (1, \infty)$  and  $\tau \in (0, \frac{1}{p} \wedge \frac{1}{p'})$ . Let  $A$  be as in [\(3.2\)](#) and let the following assumptions on the data be satisfied, as in [Lemma 3.7](#):*

- $\rho: \Omega \rightarrow \mathbb{C}^{d \times d}$  such that  $\rho_{ij} \in \mathcal{M}(H^{\tau,p}(\Omega)) \cap \mathcal{M}(H^{\tau,p'}(\Omega))$ ,
- $\beta_{\text{div}}, \beta_g \in \mathcal{M}(H^{\tau,p}(\Omega))^d \cap \mathcal{M}(H^{\tau,p'}(\Omega))^d$ ,
- $\eta \in L^d(\Omega)$ ,
- $E \subseteq \overline{\Omega}$  is a  $(d-1)$ -set and  $\varrho \in L^\infty(E; \mathcal{H}_{d-1})$ .

Suppose further that there is  $\lambda \in \mathbb{C}$  such that

$$A + \lambda \in \mathcal{L}_{\text{iso}}(W_D^{1,p}(\Omega) \rightarrow W_D^{-1,p}(\Omega)).$$

Then there is  $\bar{s} \in (0, \tau]$  such that

$$A + \lambda \in \mathcal{L}_{\text{iso}}(X_D^{1+s,p}(\Omega) \rightarrow X_D^{s-1,p}(\Omega)) \quad (s \in (-\bar{s}, \bar{s})). \quad (3.4)$$

Further, both  $\bar{s}$  and the norms of the inverse operators  $(A + \lambda)^{-1}$  between  $X_D^{s-1,p}(\Omega)$  and  $X_D^{1+s,p}(\Omega)$  for  $s \in (-\bar{s}, \bar{s})$  can be estimated uniformly in the norm of all the given data and  $\|A + \lambda\|_{W_D^{1,p}(\Omega) \rightarrow W_D^{-1,p}(\Omega)}^{-1}$ .

*Proof.* We only need to collect several results from above and combine them with the Sneiberg [Theorem 3.1](#). First, due to [Lemma 3.7](#), we already know that  $A$  gives rise to continuous linear operators  $H_D^{1+\tau,p}(\Omega) \rightarrow H_D^{\tau-1}(\Omega)$  and  $H_D^{1-\tau,p}(\Omega) \rightarrow H_D^{-1-\tau,p}(\Omega)$ , and it is clear that this extends to  $A + \lambda$ .

Second, we note that, by [Proposition 2.11](#) and [Corollary 2.12](#),

$$W_D^{1,p}(\Omega) = [H_D^{1+\tau,p}(\Omega), H_D^{1-\tau,p}(\Omega)]_{\frac{1}{2}}, \quad W_D^{-1,p}(\Omega) = [H_D^{\tau-1,p}(\Omega), H_D^{-1-\tau,p}(\Omega)]_{\frac{1}{2}}.$$

From [Corollary 3.2](#) and [Theorem 3.1](#) we thus infer that there is  $\varepsilon \in (0, \frac{1}{2}]$  such that the operators

$$A + \lambda: \begin{cases} [H_D^{1+\tau,p}(\Omega), H_D^{1-\tau,p}(\Omega)]_\delta & \rightarrow [H_D^{\tau-1,p}(\Omega), H_D^{-1-\tau,p}(\Omega)]_\delta \\ (H_D^{1+\tau,p}(\Omega), H_D^{1-\tau,p}(\Omega))_{\delta,p} & \rightarrow (H_D^{\tau-1,p}(\Omega), H_D^{-1-\tau,p}(\Omega))_{\delta,p} \end{cases}$$

remain continuously invertible for all  $\delta \in (\frac{1}{2} - \varepsilon, \frac{1}{2} + \varepsilon)$ . But according to [Proposition 2.11](#), the former spaces coincide with  $H_D^{1+s,p}(\Omega) \rightarrow H_D^{1-s,p}(\Omega)$  and the latter ones with  $W_D^{1+s,p}(\Omega) \rightarrow W_D^{1-s,p}(\Omega)$ , where we have set  $s := \tau(1 - 2\delta)$ . The range of  $\delta$  then corresponds to  $s \in (-\bar{s}, \bar{s})$  where  $\bar{s} := 2\tau\varepsilon$ . Thus we obtain exactly [\(3.4\)](#).

The claimed uniformity of  $\bar{s}$  and the norms of the inverses of  $A + \lambda$  follows immediately from [\(3.1\)](#) in [Theorem 3.1](#) and the associated norm estimate, together with the estimates on the extension and restriction of  $A$  to the Bessel scale as obtained in [Lemma 3.7](#).  $\square$



Note that [12] gives a comprehensive list of settings where the principal part  $-\nabla \cdot \rho \nabla$  (or  $-\nabla \cdot \rho \nabla + \lambda$ ) of  $A$  alone satisfies the isomorphism assumption in [Theorem 3.9](#). It thus seems appropriate to state an auxiliary result leading to the corresponding assumption for  $A$ , starting from just the principal part.

**Corollary 3.10.** *Let  $p \geq 2$ . Let  $\lambda \in \mathbb{C}$  and suppose the following on the data:*

- $\rho \in \mathcal{C}(\rho_\bullet, \rho^\bullet)$ ,
- $\beta_{\text{div}} \in L^\infty(\Omega)^d$  and there is  $\tau \in (0, \frac{1}{p})$  such that  $\beta_g \in \mathcal{M}(H_D^{\tau, p'}(\Omega))^d$ ,
- $\eta \in L^d(\Omega)$  and there exists  $\eta_\bullet \in \mathbb{R}$  such that  $\text{Re } \eta \geq \eta_\bullet$  a.e. on  $\Omega$ ,
- $E \subseteq \bar{\Omega}$  is a  $(d-1)$ -set,  $\varrho \in L^\infty(E; \mathcal{H}_{d-1})$  and  $\text{Re } \varrho \geq \varrho_\bullet \geq 0$  in the  $\mathcal{H}_{d-1}$ -a.e. sense on  $E$ .

Moreover, assume that

$$\alpha := \text{Re } \lambda + \eta_\bullet - \frac{(\|\beta_{\text{div}}\|_{L^\infty(\Omega)} + \|\beta_g\|_{L^\infty(\Omega)})^2}{2c_\bullet} \geq 0,$$

and that  $\alpha + \varrho_\bullet > 0$  if  $\lambda \neq 0$ . Then

$$-\nabla \cdot \rho \nabla + \lambda \in \mathcal{L}_{\text{iso}}(W_D^{1,p}(\Omega) \rightarrow W_D^{-1,p}(\Omega)) \implies A + \lambda \in \mathcal{L}_{\text{iso}}(W_D^{1,p}(\Omega) \rightarrow W_D^{-1,p}(\Omega))$$

with  $A$  as in (3.2).

Recall that the assumption on  $\beta_g$  implies that  $\beta_g \in L^\infty(\Omega)$ , see [Remark 3.8](#).

*Proof of Corollary 3.10.* We first intend to show that the lower order operator  $B$ , so  $B := -\nabla \cdot \beta_{\text{div}} + \beta_g \cdot \nabla + \eta + \text{tr}_E^* \varrho \text{tr}_E$ , is relatively compact on  $W_D^{-1,p}(\Omega)$  with respect to  $-\nabla \cdot \rho \nabla + \lambda$ . Let  $\tau$  be from the assumption on  $\beta_g$ . By the compactness of the embedding  $W_D^{1,p}(\Omega) \hookrightarrow H_D^{1-\tau, p}(\Omega)$ , it suffices to prove that  $B: H_D^{1-\tau, p}(\Omega) \rightarrow W_D^{-1,p}(\Omega)$  is continuous. But this is straightforward to verify from the assumptions; for the boundary operator  $\text{tr}_E^* \varrho \text{tr}_E$  we choose  $s \in (\tau, \frac{1}{p})$  and refer to the estimate (3.3) and the embeddings mentioned right below.

With  $B$  relatively compact with respect to  $-\nabla \cdot \rho \nabla + \lambda$ , it follows that  $A = -\nabla \cdot \rho \nabla + \lambda + B$  is (semi-)Fredholm on  $W_D^{1,p}(\Omega)$  with index 0, since  $-\nabla \cdot \rho \nabla + \lambda$  is so ([33, Ch. IV. Thm. 5.26]). Thus, it is enough to show that  $A$  is injective on  $W_D^{1,p}(\Omega)$ . But this follows easily using  $\rho \in \mathcal{C}(\rho_\bullet, \rho^\bullet)$  and the conditions on  $\alpha$  and  $\varrho_\bullet$ . Here we also use that  $p \geq 2$ . (Note that if  $\lambda = 0$ , then, by the isomorphism assumption,  $\mathbf{1} \notin W_D^{1,p}(\Omega)$ .)  $\square$

**Remark 3.11.** We complement the abstract results of [Theorem 3.9](#) by attaching a boundary value problem. Let for simplicity  $f \in L^p(\Omega)$  and  $g \in L^p(\Gamma; \mathcal{H}_{d-1})$  as well as  $\lambda = 0$ . Under the assumptions in [Theorem 3.9](#), the abstract problem

$$Au = f + \text{tr}_\Gamma^* g$$

admits a unique solution  $u \in H_D^{1+s,p}(\Omega)$  for some  $s > 0$ , and  $u$  depends continuously on  $f$  and  $g$ . The associated boundary value problem is

$$\begin{aligned} -\operatorname{div}(\rho \nabla u + \beta_{\operatorname{div}} u) + \beta_g \cdot \nabla u + \eta u &= f && \text{in } \Omega, \\ -\rho \nabla u \cdot \nu + \varrho u &= g && \text{on } \Gamma, \\ u &= 0 && \text{on } D. \end{aligned}$$

The connection between the abstract and boundary value problem formulation can be made precise under additional assumptions on  $\Omega$  which would allow to apply the divergence theorem; see e.g. [\[10, Ch. 1.2\]](#) or [\[20, Ch. 2.2\]](#).

## 4 The van Roosbroeck system of semiconductor equations

In this section we use [Theorem 3.9](#) to give a direct treatment of the van Roosbroeck system of semiconductor equations. Here, we focus on Boltzmanns statistics only; see however [Remark 4.18](#) below. The van Roosbroeck system was already briefly introduced in the introduction and we now give a more detailed explanation.

In the van Roosbroeck system, negative and positive charge carriers, electrons and holes, move by diffusion and drift in a self-consistent electrical field; on their way, they may recombine to charge-neutral electron-hole pairs or, vice versa, negative and positive charge carriers may be generated from charge-neutral electron-hole pairs. The electronic state of the semiconductor device  $\Omega \subset \mathbb{R}^3$  resulting from these phenomena is described by the triple  $(u_1, u_2, \varphi)$  of unknowns consisting of the densities  $u = (u_1, u_2)$  of electrons and holes and the electrostatic potential  $\varphi$ . Their evolution during the (finite) time interval  $J = (0, T)$  is then described by the equations already mentioned in the introduction, so the *Poisson equation*

$$\begin{aligned} -\operatorname{div}(\varepsilon \nabla \varphi) &= \mathfrak{d} + u_1 - u_2 && \text{in } J \times \Omega, \\ \varphi &= \varphi_D && \text{on } J \times D, \\ \nu \cdot (\varepsilon \nabla \varphi) + \varepsilon_\Gamma \varphi &= \varphi_\Gamma && \text{on } J \times \Gamma, \end{aligned} \tag{1.4a}$$

and, for  $k = 1, 2$ , the *current-continuity equations*

$$\begin{aligned} \partial_t u_k - \operatorname{div} j_k &= r^\Omega(u, \varphi) && \text{in } J \times (\Omega \setminus \Pi) \\ u_k &= U_k && \text{on } J \times D, \\ \nu \cdot j_k &= r^\Gamma(u, \varphi) && \text{on } J \times \Gamma, \\ [\nu \cdot j_k] &= r^\Pi(u, \varphi) && \text{on } J \times \Pi, \\ u_k(0) &= u_k^0 && \text{on } \Omega, \end{aligned} \tag{1.4b}$$

with the currents

$$j_k = \mu_k (\nabla u_k + (-1)^k u_k \nabla \varphi). \quad (1.4c)$$

Let us also repeat that  $\Omega \subset \mathbb{R}^3$  is a bounded domain,  $\nu$  its unit outer normal at  $\partial\Omega$  and the latter is decomposed into a Dirichlet part  $D$  and a Neumann/Robin part  $\Gamma := \partial\Omega \setminus D$ . We will require  $\Omega$  to satisfy [Assumption 2.3](#) and to have some additional but in general very mild properties, specified in [Section 4.1](#) below.

The parameters in the Poisson equation are the dielectric permittivity  $\varepsilon: \Omega \rightarrow \mathbb{R}^{3 \times 3}$  and the so-called *doping profile*  $\mathfrak{d}$ . The latter comes from impurities induced in the materials or even very small layers of different, reaction-enhancing material in the device  $\Omega$ , see [\[43\]](#) or [\[14\]](#). As such we will allow it to be located only on two-dimensional surfaces in  $\overline{\Omega}$ ; see our mathematical requirement on  $\mathfrak{d}$  in [Assumption 4.8](#) below. Moreover, in the boundary conditions,  $\varepsilon_\Gamma: \Gamma \rightarrow [0, \infty)$  represents the capacity of the part of the corresponding device surface,  $\varphi_D$  and  $\varphi_\Gamma$  are the voltages applied at the contacts of the device, thus they may depend on time. As above, we always write  $u$  for the pair of densities  $(u_1, u_2)$ .

Although we are aware of the fact that, from a physical point of view, the Dirichlet data  $\varphi_D$  in [\(1.4a\)](#) and  $U_k$  in [\(1.4b\)](#) is—at least in case of a voltage driven regime—an essential part of the model, we will focus on the case where it is zero. This is in order to make the most fundamental things in the analysis visible, for the (standard) treatment of non-zero data see [\[32\]](#) and [\[13\]](#).

The current-continuity equations feature the fluxes [\(1.4c\)](#) with the mobility tensors  $\mu_k: \Omega \rightarrow \mathbb{R}^{3 \times 3}$  for electrons and holes, and the recombination terms  $r^\Omega, r^\Gamma$  and  $r^\Pi$ . Here  $r^\Omega$  models recombination in the bulk and the normal fluxes across the exterior boundary  $\Gamma$  are balanced with surface recombination  $r^\Gamma$  taking place on  $\Gamma$ . For the physical significance of interfacial recombination induced by  $r^\Pi$  in modern devices we refer to e.g. [\[60\]](#) or [\[59, Ch. 3\]](#).

The bulk recombination term  $r^\Omega$  in [\(1.4b\)](#) can consist of rather general functions of the electrostatic potential  $\varphi$ , of the currents  $j_k$ , and of the vector of electron/hole densities  $u$ . It describes the production, or destruction, depending on the sign, of electrons and holes. Below, we collect some of the most relevant examples, covering non-radiative recombination like the Shockley-Read-Hall recombination due to phonon transition, Auger recombination (three particle transition), and Avalanche generation. See e.g. [\[19, 34, 53\]](#) and the references cited there for more information. The most familiar recombination mechanisms are the following:

- *Shockley-Read-Hall recombination* (photon transition):

$$r_{\text{SRH}}^\Omega(u) := \frac{u_1 u_2 - n_i^2}{\tau_2(u_1 + n_1) + \tau_1(u_2 + n_2)}, \quad (4.1)$$

where  $n_i$  is the intrinsic carrier density,  $n_1, n_2$  are reference densities, and  $\tau_1, \tau_2$  are the lifetimes of electrons and holes, respectively.

- *Auger recombination* (three particle transitions):

$$r_{\text{Auger}}^{\Omega}(u) = (u_1 u_2 - n_i^2)(c_1^{\text{Auger}} u_1 + c_2^{\text{Auger}} u_2), \quad (4.2)$$

where  $c_1^{\text{Auger}}$  and  $c_2^{\text{Auger}}$  are the Auger capture coefficients of electrons and holes, respectively, in the semiconductor material.

All occurring constants are parameters of the semiconductor material.

Both recombination mechanisms mentioned above depend on the carrier densities  $u$  only. This is *not* the case for the Avalanche generation term which depends also on the *gradients* of the physical quantities:

- An analytical expression for *Avalanche generation* (impact ionization), valid at least in the material cases of Silicon or Germanium, is

$$r_{\text{Ava}}^{\Omega}(u, \varphi) = c_2 |j_2| \exp\left(\frac{-a_2 |j_2|}{|\nabla \varphi \cdot j_2|}\right) + c_1 |j_1| \exp\left(\frac{-a_1 |j_1|}{|\nabla \varphi \cdot j_1|}\right). \quad (4.3)$$

Again, the parameters  $a_1, a_2 > 0$  and  $c_1, c_2$  are material-dependent. We refer to [53, p. 111/112] and references; in particular Tables 4.2-3/4.2-4, and see also [36, Ch. 17, p. 54/55].

We give more functional-analytic meaning to the recombination terms in the next section, where we collect the various assumptions on the data in (1.4).

## 4.1 Assumptions

In this section, we introduce some mathematical terminology and state mathematical prerequisites for the analysis of the van Roosbroeck system (1.4). All assumptions in this section are supposed to be valid from now on.

### 4.1.1 Assumptions on the geometry

We begin with the following geometric requirements on the domain  $\Omega$  occupied by the device. Fig. 1 shows a typical example of a semiconductor device.

**Assumption 4.1** (Geometry, extended). The set  $\Omega \subset \mathbb{R}^3$  is a bounded domain and satisfies the *thickness* condition: There exist constants  $0 < c \leq C < 1$  such that

$$c \leq \frac{|B_r(x) \cap \Omega|}{|B_r(x)|} \leq C \quad (x \in \partial\Omega, r \in (0, 1]). \quad (4.4)$$

Moreover, the following additional properties hold true for the boundary  $\partial\Omega$ :

- (i)  $D \subseteq \partial\Omega$  is a closed 2-set with  $\mathcal{H}_2(D) > 0$ . The relative boundary  $\partial D$  of  $D$  in  $\partial\Omega$  is a 1-set.

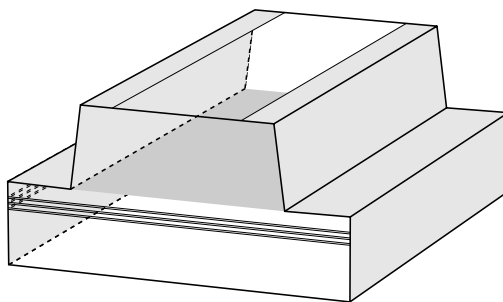

Figure 1: Scheme of a ridge waveguide quantum well laser (detail  $3.2\mu\text{m} \times 1.5\mu\text{m} \times 4\mu\text{m}$ ). The device has two material layers, the material interface is the darkly shaded plane. The top and bottom of the structure are subject to Dirichlet boundary conditions for the electrostatic potential  $\varphi$ , the remaining boundary carries Neumann boundary conditions (lightly shaded; the frontal area is kept transparent). A triple quantum well structure induced by different material layers is indicated in the lower part, corresponding to the doping  $\mathfrak{d}$ .

- (ii) There are Lipschitz charts available around  $\overline{\partial\Omega \setminus D}$ , that is, for every  $x \in \overline{\partial\Omega \setminus D}$ , there is an open neighborhood  $\mathcal{U}$  of  $x$  and a bi-Lipschitz mapping  $\phi_x: \mathcal{U} \rightarrow (-1, 1)^3$  such that  $\phi_x(x) = 0$  and  $\phi_x(\mathcal{U} \cap \Omega) = (-1, 0) \times (-1, 1)^2$ .
- (iii)  $\Pi \subset \Omega$  is a Lipschitz surface, not necessarily connected, which forms a 2-set.

**Remark 4.2.** (i) We emphasize the condition  $C < 1$  in the thickness condition (4.4) in the foregoing assumption. This requirement makes the thickness condition strictly stronger than the *interior* thickness condition for  $\partial\Omega$  which is equivalent  $\Omega$  being  $d$ -regular as mentioned in Remark 2.2. In fact, the thickness condition (4.4) implies that both  $\Omega$  and  $\Omega^c$  are  $d$ -regular ([6, Ex. 2.4]). In particular, Assumption 4.1 always implies Assumption 2.3.

- (ii) A particular case in which Assumption 4.1 is satisfied is when  $\Omega$  is a (weak) Lipschitz domain with compatibility conditions at the relative boundary  $\partial D$  of  $D$  within  $\partial\Omega$ ; such sets are often called *regular in the sense of Gröger* and have found widespread use. We refer to [22] and the introduction of [6].

Assumption 4.1 defines the general geometric framework for this section which however is restricted implicitly by Assumption 4.3 below. We are convinced that this setting is sufficiently broad to cover (almost) all relevant semiconductor geometries, in particular in view of the arrangement of  $D$  and  $\Gamma$ . Please see also the more elaborate Remark 4.4 on this topic below.

The second-order (elliptic) differential operators occurring in (1.4) will of course be considered in their weak form introduced in Definition 2.15 with the Robin boundary form realized as in Definition 2.20. We pose the following assumptions on their data:

**Assumption 4.3.** We have  $\varepsilon, \mu_1, \mu_2 \in \mathcal{C}(c_\bullet, c^\bullet)$  and  $\varepsilon_\Gamma \in L^\infty(\Gamma; \mathcal{H}_2)$  and all these functions are *real*. Moreover, the following additional properties hold true:

- (i) There is a common integrability exponent  $q \in (3, 4)$  such that

$$-\nabla \cdot \varepsilon \nabla + \text{tr}_\Gamma^* \varepsilon_\Gamma \text{tr}_\Gamma \in \mathcal{L}_{\text{iso}}(W_D^{1,q}(\Omega) \rightarrow W_D^{-1,q}(\Omega)), \quad (4.5)$$

$$-\nabla \cdot \mu_k \nabla \in \mathcal{L}_{\text{iso}}(W_D^{1,q}(\Omega) \rightarrow W_D^{-1,q}(\Omega)) \quad (k = 1, 2). \quad (4.6)$$

- (ii) There is  $\vartheta \in (0, 1 - \frac{3}{q})$  such that  $\varepsilon_{ij} \in \mathcal{M}(H^{\vartheta,q}(\Omega))$  and  $(\mu_1)_{ij}, (\mu_2)_{ij} \in \mathcal{M}(H^{\vartheta,q}(\Omega))$ .

See also [Definitions 2.14](#) and [3.6](#) for the  $\mathcal{C}(c_\bullet, c^\bullet)$  and multiplier notions. Note moreover that due to the assumption  $q \in (3, 4)$ , we have  $1 - \frac{3}{q} < \frac{1}{q} = \frac{1}{q} \wedge \frac{1}{q'}$ . Finally, we point out that while we pose quite similar assumptions on  $\varepsilon$  and  $\mu_1, \mu_2$ , the assumptions are used in a quite different way. For  $-\nabla \cdot \varepsilon \nabla + \text{tr}_\Gamma^* \varepsilon_\Gamma \text{tr}_\Gamma$ , they enable us to use the extrapolated elliptic regularity result in [Theorem 3.9](#). For  $-\nabla \cdot \mu_k \nabla$ , the isomorphism assumption (4.6) will allow to determine the domains of certain fractional powers of these operators which are of interest for classical parabolic theory for semilinear equations such as (1.4b), see [Lemma 4.16](#) below. On the other hand, the multiplier assumption on  $\mu_k$  is used to deal with the drift-structure induced by the fluxes  $j_k$  as defined in (1.4c).

Whenever we refer to the integrability  $q$  from now on, a fixed number from [Assumption 4.3](#) is meant.

**Remark 4.4.** (i) Properties (4.5) and (4.6) remain true for all  $\tilde{q} \in [2, q)$  by the Lax-Milgram lemma and interpolation ([Proposition 2.11](#)). In particular, the set of indices  $q \geq 2$  such that (4.5) and (4.6) holds true always forms an interval. Thus it is sufficient to know that each of the operators (4.5) and (4.6) is an isomorphism for *some*  $q > 3$  in order to find a *common*  $q$ . Let us moreover note that in the presence of mixed boundary conditions one cannot expect  $q \geq 4$  in [Assumption 4.3 \(i\)](#) when  $D$  and  $\Gamma$  meet due to the counterexample by Shamir [[55](#), Introduction].

- (ii) [Assumption 4.3 \(i\)](#) is fulfilled by very general classes of layered structures and additionally, if  $D$  and its complement  $\Gamma$  do not meet in a too wild manner, for the most relevant model settings. (See [[24](#)] for the latter.) A global framework has recently been established in [[12](#)]. However, [Assumption 4.3 \(i\)](#) is indeed a restriction on the class of admissible coefficient functions  $\varepsilon$  and  $\mu_k$ . For instance, it is typically not satisfied if three or more different materials meet at one edge.
- (iii) Note that it is typically not restrictive to assume that all three differential operators in (4.5) and (4.6) provide topological isomorphisms *at once* if one of them does, since this property mainly depends on the (possibly) discontinuous coefficient functions versus the geometry of  $D$ . This is determined by the material properties of the device  $\Omega$ , i.e., the coefficient functions  $\mu_1, \mu_2, \varepsilon$  will often exhibit similar discontinuities and degeneracy.

- (iv) The multiplier assumption in [Assumption 4.3 \(ii\)](#) is a very broad one and certainly fulfilled in the context of realistic semiconductor structures. Recall that, as seen in [Remark 3.8](#), the multiplier assumptions on  $\mu_1, \mu_2$  and  $\varepsilon$  hold in fact for *all* differentiability orders  $\tau \in [0, \vartheta]$ .

#### 4.1.2 Assumptions on recombination terms

We next give the assumptions for the recombination terms  $r^\Omega, r^\Pi, r^\Gamma$  in [\(1.4b\)](#). For convenience, we introduce

$$\mathbf{W}_D^{1,q}(\Omega) := W_D^{1,q}(\Omega) \times W_D^{1,q}(\Omega).$$

Note that by *locally Lipschitzian* we mean that the corresponding function is Lipschitz continuous on bounded sets.

**Assumption 4.5.** All reaction terms  $r^\Omega, r^\Pi, r^\Gamma$  map *real* functions to again *real ones*. Moreover:

- (i) The bulk reaction term  $r^\Omega$  is a locally Lipschitzian mapping

$$r^\Omega: \mathbf{W}_D^{1,q}(\Omega) \times W_D^{1,q}(\Omega) \ni (u, \varphi) \mapsto r^\Omega(u, \varphi) \in L^{\frac{q}{2}}(\Omega).$$

- (ii) The reaction term  $r^\Gamma$  on  $\Gamma$  is a locally Lipschitzian mapping

$$r^\Gamma: \mathbf{W}_D^{1,q}(\Omega) \times W_D^{1,q}(\Omega) \ni (u, \varphi) \mapsto r^\Gamma(u, \varphi) \in L^4(\Gamma; \sigma).$$

- (iii) The interfacial reaction term  $r^\Pi$  on  $\Pi$  satisfies the same assumption as  $r^\Gamma$  does, *mutatis mutandis*.

The choice of integrability 4 on  $\Gamma$  and  $\Pi$ , respectively, is connected to  $q < 4$  in [Assumption 4.3](#). This can be seen in [Lemma 4.13](#) below.

It is easy to see that the recombination terms  $r_{\text{SRH}}^\Omega$  and  $r_{\text{Auger}}^\Omega$  introduced in [\(4.1\)](#) and [\(4.2\)](#) satisfy [Assumption 4.5](#). On the other hand, validating the same for the Avalanche generation term, depending on the electric field  $\varphi$  and the currents  $j_k$ , is nontrivial, but we indeed find:

**Lemma 4.6.** *The Avalanche recombination term  $r_{\text{Ava}}^\Omega$  defined in [\(4.3\)](#) satisfies [Assumption 4.5](#).*

*Proof.* The lemma is proved in [13, Ch. 3.4]. More precisely, the current densities

$$\mathbf{W}_D^{1,q}(\Omega) \times W_D^{1,q}(\Omega) \ni (u, \varphi) \mapsto j_k = \mu_k (\nabla u_k + (-1)^k u_k \nabla \varphi) \in L^q(\Omega)$$

are locally Lipschitz continuous via the estimate

$$\begin{aligned} \|j_k(u, \varphi) - j_k(v, \psi)\|_{L^q(\Omega)} &\leq \|\mu_k\|_{L^\infty(\Omega)} \left[ \|\nabla \psi\|_{L^q(\Omega)} \|u_k - v_k\|_{L^\infty(\Omega)} \right. \\ &\quad \left. + \|\nabla u_k - \nabla v_k\|_{L^q(\Omega)} + \|u_k\|_{L^\infty(\Omega)} \|\nabla \varphi - \nabla \psi\|_{L^q(\Omega)} \right] \end{aligned}$$

and the embedding  $W_D^{1,q}(\Omega) \hookrightarrow L^\infty(\Omega)$  due to  $q > d = 3$ . It remains to connect this with [13, Lem. 3.9] where

$$\begin{aligned} \|r_{\text{Ava}}^\Omega(u, \varphi) - r_{\text{Ava}}^\Omega(v, \psi)\|_{L^{\frac{q}{2}}(\Omega)} &\lesssim \|\nabla \varphi\|_{L^q(\Omega)} \left( \|j_1(u, \varphi) - j_1(v, \psi)\|_{L^q(\Omega)} + \|j_2(u, \varphi) - j_2(v, \psi)\|_{L^q(\Omega)} \right) \\ &\quad + \left( \|j_1(v, \psi)\|_{L^q(\Omega)} + \|j_2(v, \psi)\|_{L^q(\Omega)} \right) \|\nabla \varphi - \nabla \psi\|_{L^q(\Omega)} \end{aligned}$$

is shown.  $\square$

**Remark 4.7.** It is imperative to compare the very last estimate in the foregoing proof to the Lipschitz estimate for the quadratic gradient function

$$\left\| |\nabla v_1|^2 - |\nabla v_2|^2 \right\|_{L^{\frac{q}{2}}(\Omega)} \leq \left( \|\nabla v_1\|_{L^q(\Omega)} + \|\nabla v_2\|_{L^q(\Omega)} \right) \|\nabla v_1 - \nabla v_2\|_{L^q(\Omega)},$$

which is of very similar structure. This is the connection to the quadratic gradient nonlinearity  $v \mapsto |\nabla v|^2$  which was mentioned in the introduction.

### 4.1.3 Assumptions on auxiliary data

Lastly, we give the assumptions on the doping  $\mathfrak{d}$ . It permits dopings which live in the bulk *and*, possibly, on 2-dimensional surfaces, see Lemma 4.13 below. We comment on the actual requirement in Remark 4.12 below.

**Assumption 4.8.** The doping  $\mathfrak{d}$  belongs to the space  $H_D^{-\frac{3}{q}, q}(\Omega)$ .

## 4.2 Existence and uniqueness for the abstract semilinear equation

It was already explained in the introduction that we intend to solve the van Roosbroeck system (1.4) by eliminating the electrostatic potential  $\varphi$  in (1.4b) and (1.4c) as a function of the densities  $u$ , thereby considering (1.4b) as a *semilinear* parabolic equation in the densities. Having this in mind, we give a brief discussion on the question which Banach space  $\mathbf{X} = X \oplus X$  will be adequate to consider this parabolic equation in, based on the structural- and regularity properties of the unknowns  $u, \varphi$  and the data such as  $\mathfrak{d}$ .



- In view of the jump condition on the surface  $\Pi$  on the fluxes  $j_k$  in (1.4b), it cannot be expected that  $\operatorname{div} j_k$  is a function. This excludes spaces of type  $L^p(\Omega)$ . In addition, the space  $X$  should be large enough to include distributional objects, so that the inhomogeneous Neumann datum  $r^\Gamma$  in the current-continuity equations (1.4b) and the surface recombination term  $r^\Pi$  can be included in the right-hand side of the current continuity equations.
- For our analysis, we require an adequate parabolic theory for the divergence operators on  $\mathbf{X}$ . Due to the *non-smooth geometry*, the *mixed boundary conditions* and *discontinuous coefficient functions*, this is nontrivial. The minimum needed is that the operators  $\nabla \cdot \mu_k \nabla$  generate *analytic* semigroups on  $X$ .
- For the handling of the squared gradient nonlinearity or other functions of gradients in the Avalanche and other recombination terms, it is imperative to have  $\nabla u_k(t)$  in  $L^q(\Omega)$  in every time point  $t$  at ones disposal in order to apply standard semilinear parabolic theory, see e.g. [28, Ch. 3.3] or [35, Ch. 7]. Hence, the Banach space  $X$  needs to be such that an interpolation space between the domain of  $\nabla \cdot \mu_k \nabla$  in  $X$  and  $X$  itself embeds continuously into  $W^{1,q}(\Omega)$ . But this excludes spaces of type  $X = W_D^{-1,q}(\Omega)$  since the domain of  $\nabla \cdot \mu_k \nabla$  there is at best  $W_D^{1,q}(\Omega)$  (Assumption 4.3 (i)). With this strategy, at the same time, the space  $X$  needs to be sufficiently large for the embedding  $L^{q/2}(\Omega) \hookrightarrow X$  to hold to include the pointwise quadratic gradient.

We will choose  $X$  as an interpolation space between  $W_D^{-1,q}(\Omega)$  and  $L^q(\Omega)$ . This will yield a framework in which the requirements listed above are indeed satisfied, see Lemmas 4.13, 4.15 and 4.16 below.

To this end, we first quote the *nonsymmetric* interpolation result which will allow us to identify the designated (interpolation) space  $X$  with a space from the Bessel scale. This proposition is the only point where the strengthened geometric assumptions in Assumption 4.1 compared to Assumption 2.3 are needed. The primal interpolation result is quoted from [6], and the dual scale is obtained in the same manner as done for proof of Corollary 2.12.

**Proposition 4.9** (Interpolation [6, Thm. 1.1]). *Let  $p \in (1, \infty)$  and  $\theta \in (0, 1)$ , and let  $E \subset \bar{\Omega}$  be a  $(d-1)$ -set. Then*

$$[W_E^{1,p}(\Omega), L^p(\Omega)]_\theta = \begin{cases} H_E^{1-\theta,p}(\Omega) & \text{if } \theta < 1 - \frac{1}{p} \\ H^{1-\theta,p}(\Omega) & \text{if } \theta > 1 - \frac{1}{p} \end{cases}$$

and accordingly

$$[W_E^{-1,p}(\Omega), L^p(\Omega)]_\theta = \left( [W_E^{1,p'}(\Omega), L^{p'}(\Omega)]_\theta \right)^* = \begin{cases} H_E^{\theta-1,p}(\Omega) & \text{if } \theta < \frac{1}{p} \\ H^{\theta-1,p}(\Omega) & \text{if } \theta > \frac{1}{p}. \end{cases}$$

Moreover, let us reiterate the following immediate consequence of [Assumption 4.3](#) and [Theorem 3.9](#), where  $\vartheta$  is the number from [Assumption 4.3 \(ii\)](#):

**Lemma 4.10.** *There is a number  $\bar{s} \in (0, \vartheta]$  such that the operator  $-\nabla \cdot \varepsilon \nabla + \text{tr}_\Gamma^* \varepsilon_\Gamma \text{tr}_\Gamma$  is a topological isomorphism between  $H_D^{1+s,q}(\Omega)$  and  $H_D^{s-1,q}(\Omega)$  for all  $s \in [0, \bar{s})$ .*

Finally, we define the Banach space  $\mathbf{X}$  in which we intend to investigate the parabolic equation:

**Definition 4.11.** Let  $\bar{s}$  be the number from [Lemma 4.10](#). We fix  $\tau \in (0, \bar{s})$  and define

$$X := [L^q(\Omega), W_D^{-1,q}(\Omega)]_{1-\tau,q} = H_D^{\tau-1,q}(\Omega) \quad \text{and} \quad \mathbf{X} := X \oplus X.$$

The identity of the interpolation space and  $H_D^{\tau-1,q}(\Omega)$  follows from [Proposition 4.9](#).

**Remark 4.12.** Due to the assumptions on  $\vartheta$ , we have  $\tau \in (0, 1 - \frac{3}{q})$ . In particular,  $\tau - 1 < -3/q$ , thus  $H^{-3/q,q}(\Omega) \hookrightarrow H_D^{\tau-1,q}(\Omega) = X$ , and so  $\mathfrak{d} \in X$  by [Assumption 4.8](#).

It remains to verify that  $X$  or  $\mathbf{X}$  satisfy the requirements we established above. The first lemma joins [Remark 4.12](#) in showing that  $X$  is sufficiently large for our means.

**Lemma 4.13.** *There holds  $L^{\frac{q}{2}}(\Omega) \hookrightarrow X$ . Moreover, the adjoint trace mappings  $\text{tr}_\Gamma^*: L^4(\Gamma; \mathcal{H}_2) \rightarrow X$  and  $\text{tr}_\Pi^*: L^4(\Pi; \mathcal{H}_2) \rightarrow X$  give rise to continuous embeddings.*

*Proof.* The first embedding follows from taking the adjoint of the Sobolev embedding  $H_D^{3/q,q'}(\Omega) \hookrightarrow L^{\frac{q}{q-2}}(\Omega)$  and the observation in [Remark 4.12](#).

Continuity of the adjoint trace is proven in [[13](#), Lem. 4.4] by showing that

$$\text{tr}_\Gamma: H_D^{\frac{3}{q},q'}(\Omega) \rightarrow L^{\frac{4}{3}}(\Gamma; \mathcal{H}_2) \quad \text{and} \quad \text{tr}_\Pi: H_D^{\frac{3}{q},q'}(\Omega) \rightarrow L^{\frac{4}{3}}(\Pi; \mathcal{H}_2) \quad (4.7)$$

are continuous, and then taking adjoints. We give a quick additional proof of (4.7) based on the trace theorem from [Corollary 2.19](#): The condition  $q \in (3, 4)$  implies that  $\frac{1}{q'} < \frac{3}{q}$ , hence we can find  $s \in (\frac{1}{q'}, \frac{3}{q})$  so that  $H^{3/q,q'}(\Omega) \hookrightarrow W^{s,q'}(\Omega)$ . Now [Corollary 2.19](#) gives the result because it says that  $\text{tr}_\Gamma$  maps  $W^{s,q'}(\Omega)$  continuously into  $L^{q'}(\Gamma)$  when  $s > \frac{1}{q'}$ ; it remains only to observe that  $q' > \frac{4}{3}$ . The reasoning for  $\text{tr}_\Pi$  is completely analogous because [Corollary 2.19](#) is valid for  $(d-1)$ -regular sets  $E \subset \bar{\Omega}$ .  $\square$

[Lemma 4.13](#) puts us in the position to establish the functional-analytic setting for the van Roosbroeck system (1.4). Recall also [Lemma 4.10](#).

**Definition 4.14** (Solution concept). Define the mapping  $v \mapsto \varphi(v)$  by

$$v \mapsto \varphi := (-\nabla \cdot \varepsilon \nabla + \text{tr}_\Gamma^* \varepsilon_\Gamma \text{tr}_\Gamma)^{-1} (\mathfrak{d} - v_1 + v_2) \quad (4.8)$$

and set

$$r(v) := r^\Omega(v, \varphi(v)) + \text{tr}_\Gamma^* r^\Gamma(v, \varphi(v)) + \text{tr}_\Pi^* r^\Pi(v, \varphi(v)).$$

Then we say that a function  $u = (u_1, u_2): [0, T^\bullet) \rightarrow \mathbf{X}$  is a *solution to the van Roosbroeck system* (1.4), if  $u(0) = u^0$  and

$$u'_k(t) - \nabla \cdot \mu_k \nabla u_k(t) = (-1)^{k+1} \nabla \cdot u_k(t) \mu_k \nabla \varphi(u(t)) + r(u(t)) \quad \text{in } X \quad (k = 1, 2)$$

for all  $t \in (0, T_\bullet)$ , where  $T_\bullet \in (0, T]$ .

Before we prove existence and uniqueness of a solution in the sense of [Definition 4.14](#), we further collect some results about the elliptic operators  $-\nabla \cdot \mu_k \nabla$ . In the second part, we make use of the co-restriction of  $-\nabla \cdot \mu_k \nabla: W_D^{1,q}(\Omega) \rightarrow W_D^{-1,q}(\Omega)$  to  $L^q(\Omega)$ , considered as a closed operator in that space, and analogously for  $X$ .

**Lemma 4.15.** (i) *The square root  $(-\nabla \cdot \mu_k \nabla)^{-1/2}$  provides a topological isomorphism between  $W_D^{-1,q}(\Omega)$  and  $L^q(\Omega)$ .*

(ii) *The operators  $\nabla \cdot \mu_k \nabla$  are generators of analytic semigroups and their negatives admit bounded imaginary powers on  $L^q(\Omega)$  space, on  $W_D^{-1,q}(\Omega)$ , and also on  $X$ .*

*Proof.* (i) is [15, Thms. 1.2/1.6], see also [2, Thm. 5.1]. (ii): The proof for both properties works in the same way: First, the property is established on  $L^q(\Omega)$ , then the square root isomorphism from (i) is used to transfer the property to  $W_D^{-1,q}(\Omega)$ , and the  $X$  case is finally obtained by interpolation.

For the generator property on  $L^q(\Omega)$ , we refer to [18, Thm. 3.1] and carry over the equivalent resolvent estimates ([44, Thm. 1.45]) to  $W_D^{-1,q}(\Omega)$ . Interpolation is then easy.

Regarding bounded imaginary powers, we refer to [18, Cor. 3.4] for the  $L^q(\Omega)$  case. The transfer to  $W_D^{-1,q}(\Omega)$  is provided by [11, Prop. 2.11]. Finally, interpolation works due to [23, Cor. 7.1.17].  $\square$

We finally determine the domain of a particular fractional power of  $-\nabla \cdot \mu_k \nabla$  to be  $W_D^{1,q}(\Omega)$  which is one of the cornerstones in the treatment of equations with nonlinear gradient terms. Here,  $\text{dom}_X(-\nabla \cdot \mu_k \nabla)$  denotes the domain of the corestriction of  $-\nabla \cdot \mu_k \nabla$  to  $X = H_D^{\tau-1,q}(\Omega) \subset W_D^{-1,q}(\Omega)$ .

**Lemma 4.16.** *One has*

$$[\text{dom}_X(-\nabla \cdot \mu_k \nabla), X]_{\frac{\tau}{2}} = \text{dom}_X((-\nabla \cdot \mu_k \nabla)^{1-\frac{\tau}{2}}) = W_D^{1,q}(\Omega). \quad (4.9)$$

*Proof.* The first equality in (4.9) follows from [57, Ch. 1.15.3] due to the *bounded imaginary powers* property of  $-\nabla \cdot \mu_k \nabla$  provided by Lemma 4.15. Moreover, without loss of generality reversing the interpolation order, we have

$$\begin{aligned} X &= [W_D^{-1,q}(\Omega), L^q(\Omega)]_\tau = [W_D^{-1,q}(\Omega), \text{dom}_{W_D^{-1,q}(\Omega)}((-\nabla \cdot \mu_k \nabla)^{1/2})]_\tau \\ &= \text{dom}_{W_D^{-1,q}(\Omega)}((-\nabla \cdot \mu_k \nabla)^{\tau/2}). \end{aligned}$$

Now use Assumption 4.3 and apply  $(-\nabla \cdot \mu_k \nabla)^{-1} \in \mathcal{L}_{\text{iso}}(W_D^{-1,q}(\Omega) \rightarrow W_D^{1,q}(\Omega))$  to obtain the second equality in (4.9).  $\square$

We are not able to formulate and prove the main result.

**Theorem 4.17** (Local-in-time wellposedness). *Suppose that  $u^0 = (u_1^0, u_2^0) \in \mathbf{W}_D^{1,q}(\Omega)$ . Then the van Roosbroeck system (1.4) admits a unique classical local-in-time solution  $u$  in the sense of Definition 4.14. That is, there is  $T_\bullet \in (0, T]$  such that*

$$u \in C^{1-\frac{\tau}{2}}([0, T_\bullet]; \mathbf{X}) \cap C([0, T_\bullet]; \mathbf{W}_D^{1,q}(\Omega)) \cap C^1((0, T_\bullet]; \mathbf{X}).$$

*The mapping  $u^0 \mapsto u$  is Lipschitz continuous from a neighbourhood of  $u^0$  in  $\mathbf{W}_D^{1,q}(\Omega)$  to  $C([0, T_\bullet]; \mathbf{X})$ . Moreover, if  $u^0$  is real, then  $u$  is real on the interval of existence.*

*Proof.* With the preparatory work done, we can rely on standard semilinear parabolic theory as established in [28, Ch. 3.3], [45, Ch. 6.3] or [35, Ch. 7] to obtain the local-in-time solution with the announced regularity. Indeed, we already know that each of the operators  $\nabla \cdot \mu_k \nabla$  generates a semigroup which is analytic on  $X$ . Clearly, the diagonal operator matrix  $\mathcal{A}$  induced by  $\nabla \cdot \mu_k \nabla$  then also generates an analytic semigroup on  $\mathbf{X}$ . It remains to establish that the right-hand sides in the reduced problem as defined in Definition 4.14 are locally Lipschitz continuous on the  $\mathbf{X}$ -domain of a true fractional power  $\mathcal{A}^\alpha$  of  $\mathcal{A}$ . In view Lemma 4.16, we focus on  $\alpha = 1 - \frac{\tau}{2}$  and on obtaining the Lipschitz property on  $\mathbf{W}_D^{1,q}(\Omega)$ . This is also compatible with the assumed initial value regularity. (Here, note that  $\text{dom}_{\mathbf{X}} \mathcal{A}$  is dense in  $\mathbf{W}_D^{1,q}(\Omega)$  due to the interpolation identity (4.9).)

For the reaction terms  $r^\Omega, r^\Gamma, r^\Pi$ , this is by Assumption 4.5 and Lemma 4.6. We only need to consider the drift-diffusion terms. It is clear that

$$\mathbf{W}_D^{1,q}(\Omega) \ni v \mapsto \varphi(v) = (-\nabla \cdot \varepsilon \nabla + \text{tr}_\Gamma^* \varepsilon_\Gamma \text{tr}_\Gamma)^{-1} (\mathfrak{d} - v_1 + v_2) \in H_D^{1+\tau,q}(\Omega) \quad (4.10)$$

as defined in (4.8) is Lipschitz continuous, recall Lemma 4.10 and Remark 4.12. Thus, quite similar to the estimate in the proof of Lemma 4.6, we obtain for  $v, w \in \mathbf{W}_D^{1,q}(\Omega)$ :

$$\begin{aligned} &\|\nabla \cdot u_k \mu_k \nabla \varphi(w) - \nabla \cdot v_k \mu_k \nabla \varphi(v)\|_X \\ &= \|\nabla \cdot w_k \mu_k \nabla (\varphi(w) - \varphi(v)) - \nabla \cdot (v_k - w_k) \mu_k \nabla \varphi(v)\|_X \quad (4.11) \end{aligned}$$

and of course we split the latter with the triangle inequality. From there, we rely on (4.10) and multiplier properties of  $\mu_k$  and  $w_k$ . This is because if  $\omega \in \mathcal{M}(H^{s,q}(\Omega))$  and  $\psi \in H_D^{1+s,q}(\Omega)$  for some  $s \in (0, \frac{1}{q})$ , then using Lemma 3.5 and estimating as in the proof of Lemma 3.7, we find

$$\|\nabla \cdot \omega \nabla \psi\|_{H_D^{1-s,q}(\Omega)} \leq \|\omega\|_{\mathcal{M}(H^{s,q}(\Omega))} \|\psi\|_{H_D^{1+s,q}(\Omega)}, \quad (4.12)$$

and  $H_D^{1+s,q}(\Omega)$  is the biggest space for  $\psi$  we can determine for which such an estimate works. We had in fact assumed that  $\mu_k$  is a multiplier on  $H_D^{\tau,q}(\Omega)$  in Assumption 4.3 (ii). For  $w_k$ , we observe that  $W_D^{1,q}(\Omega) \hookrightarrow C^{1-3/q}(\Omega)$  and  $\tau < 1 - 3/q$  by assumption, see Remark 4.12. Hence  $C^{1-3/q}(\Omega) \hookrightarrow \mathcal{M}(H^{\tau,q}(\Omega))$  as noted in Remark 3.8 and  $w_k \in W_D^{1,q}(\Omega)$  is also a multiplier on  $H^{\tau,q}(\Omega)$ . Thus, via (4.12)

$$\begin{aligned} \|\nabla \cdot w_k \mu_k \nabla (\varphi(w) - \varphi(v))\|_X &\leq \|w_k \mu_k\|_{\mathcal{M}(H^{\tau,q}(\Omega))} \|\varphi(w) - \varphi(v)\|_{H_D^{1+\tau,q}(\Omega)} \\ &\lesssim \|w_k\|_{W_D^{1,q}(\Omega)} \|\varphi(w) - \varphi(v)\|_{H_D^{1+\tau,q}(\Omega)} \end{aligned} \quad (4.13)$$

In a similar fashion, the second term is estimated by

$$\begin{aligned} \|\nabla \cdot (v_k - w_k) \mu_k \nabla \varphi(v)\|_X &\leq \|\mu_k\|_{\mathcal{M}(H^{\tau,q}(\Omega))} \|\varphi(v)\|_{H_D^{1+\tau,q}(\Omega)} \|w_k - v_k\|_{\mathcal{M}(H^{\tau,q}(\Omega))} \\ &\lesssim \|\varphi(v)\|_{H_D^{1+\tau,q}(\Omega)} \|w_k - v_k\|_{W_D^{1,q}(\Omega)} \end{aligned} \quad (4.14)$$

Estimating (4.11) further using (4.13) and (4.14) and using Lipschitz continuity of  $v \mapsto \varphi(v)$ , we obtain the desired *local* Lipschitz continuity on  $\mathbf{W}_D^{1,q}(\Omega)$ . Hence standard semilinear theory as in the works mentioned at the beginning of the proof shows that a solution  $u$  to the semiconductor equations in the sense of Definition 4.14 with the announced exists locally in time.

Finally, let us show that this solution  $u$  is indeed a *real* one. In fact, this is implied by the following facts:

- (i) The semigroups generated by  $\nabla \cdot \mu_k \nabla$  are *real* ones, that is, they transform elements from the real part of  $W_D^{-1,q}(\Omega)$  into *real* functions. (See [44, Ch. 2.2/4.2].) Clearly, this transfers to  $\mathcal{A}$  on  $\mathbf{X}$ .
- (ii) Since the initial values  $u_1^0$  and  $u_2^0$  were supposed to be *real*, the fixed point procedure used to construct a solution in the classical proof in [45, Thm. 6.3.1] can in fact be done in the *real* part of  $\mathbf{X}$ .

This completes the proof.  $\square$

**Remark 4.18.** (i) Let us point out that the Lipschitz estimate in the proof of the main Theorem 4.17 *only* works so smoothly using (4.12) because we in fact know that (4.10) holds with the  $H_D^{1+\tau,q}(\Omega)$  image space, which in turn is a consequence of extrapolated elliptic regularity as established in Theorem 3.9, see Lemma 4.10. It was already mentioned in the foregoing proof that  $H_D^{1+\tau,q}(\Omega)$  is exactly the largest space for which an estimate of the form (4.12) can work with  $\omega = w_k \mu_k$ . Note here that  $w_k$  is not fixed and does not necessarily admit a strictly positive lower bound.

- (ii) The presented real world example is one among many others which can be treated the same way. We focused here—in contrast to [13]—on the case where the chemical potential and the densities in the semiconductor model are related by Boltzmann statistics, i.e., where their relating function is the exponential (or logarithm, depending on the point of view). This has the consequence that the resulting evolution equation for the densities is a *semilinear* one. In the general case of Fermi-Dirac statistics, the corresponding evolution equation will be a *quasilinear* one. However, such a quasilinear equation can also be treated in a quite similar manner to the above. One would use Prüss’ pioneering theorem ([47]) as the abstract tool, based on the fact that the operators  $-\nabla \cdot \mu_k \nabla$  in fact even satisfy maximal parabolic regularity on the spaces  $X = H_D^{\tau-1,q}(\Omega)$ , see [2, Ch. 11] and [25, Lemma 5.3]. The analysis above shows that exactly the extrapolation result [Theorem 3.9](#) allows to eliminate the electrostatic potential implicitly, in a very much simpler way as done before, compare [13, 32].
- (iii) It is well known that the solutions of *nonlinear* parabolic equations possibly cease to exist after finite time. This is even the case if the nonlinearity only depends on the unknown itself instead of its gradient, see e.g. the classical paper [4]. Of course, this is even more so the case if the nonlinearity contains gradient dependent terms; we refer to [50, Ch. IV] and references therein. Therefore the question of *global* existence for the solution in the general context of [Theorem 4.17](#) seems out of reach. For related arguments from physics, see [36, p. 55].
- (iv) It is possible to relax the requirements on the initial data when working in function spaces with temporal weights, see [49]. Since our impetus was to demonstrate the power of the extrapolated regularity result for elliptic operators in a real-world problem, this is out of scope here. See however [35, Thm. 7.1.6].

## References

- [1] D. R. Adams and L. I. Hedberg: *Function spaces and potential theory*. Grundlehren der mathematischen Wissenschaften Vol. 314, Springer, Berlin (1996).
- [2] P. Auscher, N. Badr, R. Haller-Dintelmann, J. Rehberg: The square root problem for second-order, divergence form operators with mixed boundary conditions on  $L^p$ . *J. Evol. Equ.* 15 No. 1 (2015), 165–208.
- [3] P. Auscher, S. Bortz, M. Egert, O. Saari: Nonlocal self-improving properties: a functional analytic approach. *Tunis. J. Math.* 1 No. 2 (2019), 151–183.
- [4] P. Baras; L. Cohen: Complete blow-up after  $T_{max}$  for the solution of a semilinear heat equation. *J. Funct. Anal.* 71 (1987), 142–174.
- [5] S. Bechtel: Intrinsic characterization of Sobolev spaces with boundary conditions. *arXiv: 2002.08656* (2020).

- [6] S. Bechtel, M. Egert: Interpolation theory for Sobolev functions with partially vanishing trace on irregular open sets. *J. Fourier Anal. Appl.* 25 (2019), 2733–2781.
- [7] M. Biegert: On traces of Sobolev functions on the boundary of extension domains. *Proc. Amer. Math. Soc.* 137 No. 12 (2009), 4169–4176.
- [8] P. Biler, M. Guedda,, G. Karch: Asymptotic properties of solutions of the viscous Hamilton-Jacobi equation. *J. Evol. Equ.* 4 No. 1 (2004), 75–97.
- [9] K. Brewster, D. Mitrea, I. Mitrea, M. Mitrea: Extending Sobolev Functions with Partially Vanishing Traces from Locally  $(\epsilon, \delta)$ -Domains and Applications to Mixed Boundary Problems. *J. Funct. Anal.* 266 No. 7 (2014), 4314–4421.
- [10] P. G. Ciarlet: *The finite element method for elliptic problems*. Studies in Mathematics and its Applications 4, North-Holland, Amsterdam (1978).
- [11] R. Denk, M. Hieber, J. Prüss:  $\mathcal{R}$ -boundedness, Fourier multipliers and problems of elliptic and parabolic type. *Mem. Am. Math. Soc.* 166 no. 788 (2003).
- [12] K. Disser, H.-C. Kaiser, J. Rehberg: Optimal Sobolev regularity for linear second-order divergence elliptic operators occurring in real-world problems, *SIAM J. Math. Anal.* 47 No. 3 (2015), 1719–1746.
- [13] K. Disser and J. Rehberg: The 3D transient semiconductor equations with gradient-dependent and interfacial recombination. *Math. Models Methods Appl. Sci.* 29 (2019), 1819–1851.
- [14] D. W. Drumm, L. C. L. Hollenberg, M. Y. Simmons and M. Friesen. Effective mass theory of monolayer  $\delta$  doping in the high density limit. *Phys. Rev. B* 85 155419 (2012).
- [15] M. Egert:  $L^p$ -estimates for the square root of elliptic systems with mixed boundary conditions. *J. Differential Equations* 265 (2018), 1279–1323.
- [16] M. Egert, R. Haller-Dintelmann, P. Tolksdorf: The Kato square root problem for mixed boundary conditions. *J. Funct. Anal.* 267 No. 5 (2014), 1419–1461.
- [17] J. Elschner, J. Rehberg, G. Schmidt: Optimal regularity for elliptic transmission problems including  $C^1$  interfaces. *Interfaces Free Bound.* 9 No. 2 (2007), 233–252.
- [18] A.F.M. ter Elst, J. Rehberg, A. Linke: On the numerical range of sectorial forms, [arXiv:1912.09169](https://arxiv.org/abs/1912.09169) (2019).
- [19] H. Gajewski: Analysis und Numerik von Ladungstransport in Halbleitern (Analysis and numerics of carrier transport in semiconductors), *Mitt. Ges. Angew. Math. Mech.* 16 No. 1 (1993), 35–57 (German).
- [20] H. Gajewski, K. Gröger, K. Zacharias: *Nichtlineare Operatorgleichungen und Operatordifferentialgleichungen*. Mathematische Lehrbücher und Monographien, II. Abteilung Mathematische Monographien 38. Akademie-Verlag, Berlin (1974). (German)

- [21] B.H. Gilding, M. Guedda, R. Kersner: The Cauchy problem for  $u_t = \Delta u + |\nabla u|^q$ . *J. Math. Anal. Appl.* 284 No. 2 (2003), 733–755.
- [22] K. Gröger: A  $W^{1,p}$ -estimate for solutions to mixed boundary value problems for second order elliptic differential equations. *Math. Ann.* 283 No. 4 (1989), 679–687.
- [23] M. Haase: *The functional calculus for sectorial operators*. Operator Theory: Advances and Applications 169. Birkhäuser, Basel (2006).
- [24] R. Haller-Dintelmann, H.-C. Kaiser, J. Rehberg. Elliptic model problems including mixed boundary conditions and material heterogeneities. *J. Math. Pures Appl.* 89 No. 1 (2008), 25–48.
- [25] R. Haller-Dintelmann, J. Rehberg: Maximal parabolic regularity for divergence operators including mixed boundary conditions. *J. Differ. Equations* 247 No. 5 (2009), 1354–1396.
- [26] R. Haller-Dintelmann, A. Jonsson, D. Knees, J. Rehberg: Elliptic and parabolic regularity for second order divergence operators with mixed boundary conditions. *Math. Methods Appl. Sci.* 39 No. 17 (2016), 5007–5026.
- [27] R. Haller-Dintelmann, H. Meinschmidt, W. Wollner: Higher regularity for solutions to elliptic systems in divergence form subject to mixed boundary conditions. *Ann. Mat. Pura Appl.* 198 No. 4 (1923-) (2019), 1227–1241.
- [28] D. Henry: *Geometric theory of semilinear parabolic equations*. Lecture Notes in Mathematics 840. Springer, Berlin-Heidelberg-New York (1981).
- [29] D. Horstmann, H. Meinschmidt, J. Rehberg: The full Keller-Segel model is well-posed on non-smooth domains. *Nonlinearity* Vol. 31 No. 4 (2018), 1560–1592.
- [30] F. Jochmann: A  $H^s$  regularity result for the gradient of solutions to elliptic equations with mixed boundary conditions. *J. Math. Anal. Appl.* 238 (1999), 429–450.
- [31] A. Jonsson, H. Wallin: *Function spaces on subsets of  $\mathbb{R}^n$* . Harwood Academic Publishers, Chur-London-Paris-Utrecht-New York (1984).
- [32] H-C. Kaiser, H. Neidhardt, J. Rehberg: Classical solutions of drift-diffusion equations for semiconductor devices: The two-dimensional case. *Nonlinear Anal., Theory Methods Appl., Ser. A, Theory Methods* 71 No. 5-6 (2009), 1584–1605.
- [33] T. Kato: *Perturbation theory for linear operators*. Springer (1976).
- [34] P.T. Landsberg: *Recombination in Semiconductors*. Cambridge University Press, Cambridge (1991).
- [35] A. Lunardi: *Analytic Semigroups and Optimal Regularity in Parabolic Problems*, Birkhäuser, Basel (1995).
- [36] P.A. Markowich: *The stationary Semiconductor Device Equations*, Springer-Verlag, Wien (1986).



- [37] J. Marschall: Nonregular Pseudo-Differential Operators. *Z. Anal. Anwendungen* 15 (1996), 109–148.
- [38] V. Maz'ya, T. O. Shaposhnikova, T. O.: *Theory of Sobolev Multipliers*. Grundlehren der mathematischen Wissenschaften, Springer, Berlin Heidelberg (2009).
- [39] H. Meinschmidt, C. Meyer, J. Rehberg: Optimal Control of the Thermistor Problem in Three Spatial Dimensions, Part 1: Existence of Optimal Controls. *SIAM J. Control Optim.* 55 No. 5 (2017), 2876—2904.
- [40] H. Meinschmidt, C. Meyer, J. Rehberg: Optimal Control of the Thermistor Problem in Three Spatial Dimensions, Part 2: Optimality Conditions. *SIAM J. Control Optim.* 55 No. 4 (2017), 2368–2392.
- [41] H. Meinschmidt, J. Rehberg: Hölder-estimates for non-autonomous parabolic problems with rough data. *Evol. Equ. Control Theory* 5 (2016), 147–184.
- [42] N. G. Meyers: An  $L^p$ -estimate for the gradient of solutions of second order elliptic divergence equations. *Ann. Scuola Norm.-Sci. Série 3* 17 No. 3 (1963), 189–206.
- [43] A. M. Nazmul, T. Amemiya, Y. Shuto, S. Sugahara, and M. Tanaka: High Temperature Ferromagnetism in GaAs-Based Heterostructures with Mn- $\delta$  Doping, *Phys. Rev. Lett.* 95 017201 (2005). Erratum *Phys. Rev. Lett.* 96 149901 (2006).
- [44] E. Ouhabaz: *Analysis of Heat Equations on Domains*. London Mathematical Society Monographs Series Vol. 31, Princeton University Press, Princeton (2005).
- [45] A. Pazy: *Semigroups of linear operators and applications to partial differential equations*. Springer (1983).
- [46] A. Porretta: Weak solutions to Fokker-Planck equations and mean field games. *Arch. Ration. Mech. Anal.* 216 No. 1 (2015), 1–62.
- [47] J. Prüss, Maximal regularity for evolution equations in  $L^p$ -spaces, *Conf. Semin. Mat. Univ. Bari* 285 (2002), 1–39.
- [48] J. Prüss, R. Schnaubelt: Solvability and Maximal Regularity of Parabolic Evolution Equations with Coefficients Continuous in Time. *J. Math. Anal. Appl.* 256 (2001), 405–430.
- [49] J. Prüss, G. Simonett: Maximal regularity for evolution equations in weighted  $L^p$ -spaces. *Arch. Math.* 82, No. 5 (2004), 415–431.
- [50] P. Quittner, P. Souplet: *Superlinear Parabolic Problems*. Birkhäuser, Basel (2019).
- [51] T. Runst, W. Sickel: *Sobolev Spaces of Fractional Order, Nemytskij Operators, and Nonlinear Partial Differential Equations*. Walter de Gruyter, Berlin, New York (1996).
- [52] G. Savaré: Regularity Results for Elliptic Equations in Lipschitz Domains. *J. Funct. Anal.* 152 (1998), 178–201.

- [53] S. Selberherr: *Analysis and simulation of semiconductor devices*. Springer, Wien (1984).
- [54] W. Sickel: Pointwise multipliers of Lizorkin-Triebel spaces. In: The Maz'ya anniversary collection. *Op. Theory, Adv. Appl.* Vol. 110, Birkhäuser, Basel (1999).
- [55] E. Shamir: Regularization of mixed second-order elliptic problems. *Israel J. Math.* 6 (1968), 150–168.
- [56] I. J. Sneiberg: Spectral properties of linear operators in interpolation families of Banach spaces. *Mat. Issled.* 9 No. 2 (1974), 214–229.
- [57] H. Triebel: A note on function spaces in rough domains. (English. Russian original) *Proc. Steklov Inst. Math.* 293 (2016), 338–342. Translation from *Tr. Mat. Inst. Steklova* 293 (2016), 346–351.
- [58] H. Triebel: *Interpolation theory, function spaces, differential operators*. North Holland Publishing Company, Amsterdam-New York-Oxford (1978).
- [59] K. Viswanath: *Handbook of Surfaces and Interfaces of Materials*. Edited by H.S. Nalwa. Vol. 1, Ch. 3: *Surface and Interfacial Recombination in Semiconductors*, Academic Press (2001).
- [60] J. Xiang, Y. Li, F. Huang, D. Zhong: Effect of interfacial recombination, bulk recombination and carrier mobility on the J–V hysteresis behaviors of perovskite solar cells: a drift-diffusion simulation study. *Phys. Chem. Chem. Phys.* 21 (2019), 17836–17845.